

Sunamp

Keep these instructions in a safe place for future reference









UniQ HW +iLTHP Heat Battery Installation and User Manual



Safety Notice

Symbols and Notices Used and Their Meanings

Symbols			
			
Warning	Electric Hazard	Take note	Cross reference
Warning Notices	Consequences	Likelihood	
 WARNING	Death/serious injury (irreversible)	Potential risk	
 CAUTION	Damage/minor injury (reversible)	Potential risk	



DO NOT install outdoors. This product is for indoor use only.

Improper installation, adjustment, alteration, service or maintenance can cause property damage, injury and death.

ONLY competent persons who are suitably qualified to carry out plumbing and electrical work and have successfully completed product training by Sunamp Ltd or an authorised training partner may undertake installations, repairs or relocations.

The system must be earthed correctly and have its own independent electrical supply with correct voltage and circuit breakers.

The point of connection to the mains should be readily accessible and adjacent to the Heat Battery installation. Connection must allow isolation of the electrical supply. Disconnection must be achieved by a fused spur in accordance with the wiring rules.

Only use this product for the intended purpose described in this manual.

There are no user serviceable, adjustable or settable parts in this product.

Read the full Safety Instructions in Section 1 of this manual before you install this product.

Document Purpose

To instruct *competent* persons on how to safely install **UniQ HW +iLTHP Heat Batteries**. *Competent* persons are those suitably qualified to carry out plumbing and electrical work and have successfully completed product training by Sunamp Ltd or an authorised training partner.

Contents

1	Safety Instructions	4
1.1	Intended Use	4
1.2	Pre-installation Safety Advice	4
1.3	Mechanical Safety.....	4
1.4	Electrical Safety.....	5
1.5	Water Safety	5
1.6	User Competence, Qualification, and Approval	6
1.7	Compliance with Safety Laws and Regulations.....	6
1.8	Post-Installation Safety	6
1.9	Repair and Relocation	7
2	UniQ HW +iLTHP Heat Battery Overview	8
2.1	Introduction.....	8
2.2	Product Overview	9
2.3	Product Identification.....	11
2.4	Accessories and Parts.....	12
2.5	Technical Specifications	13
2.6	Pressure Loss Characteristics.....	16
3	Installation	18
3.1	Installation Process.....	18
3.2	Water Supply Requirements.....	22
3.3	Location and Space Requirements.....	23
3.4	Hydraulic Requirements.....	25
3.5	Temperature and Insulation Requirements.....	25
3.6	Electrical and Wiring Requirements.....	26
3.7	Wiring Option 1 – HW +iLTHP Samsung Low Temperature Heat Pump	29
3.8	Wiring Option 2 – HW +iLTHP Daikin Low Temperature Heat Pump	31
4	Commissioning	35
4.1	Preparation	35
4.2	Process.....	35
5	Operation	37
5.1	Switch On/Off	37
5.2	LED Indicators and Status.....	37
5.3	Troubleshooting	38
6	Maintenance	40
6.1	Removal of Lids.....	40
6.2	Cleaning	40
6.3	Warranty.....	41
7	Recycling and Disposal	41

1 Safety Instructions



Sunamp Ltd is not responsible for the failure of components not specified in this manual and/or supplied by other manufacturers.

1.1 Intended Use

The intended use of the **UniQ HW +iLTHP** range of products is for the provision of hot water for domestic purposes by means of using a low temperature heat pump as a main heat source, the heat battery can also be electrically charged by a heating element as a backup source.

1.2 Pre-installation Safety Advice

- Sunamp Ltd is not responsible for the selection, specification or effectiveness of equipment, unless stated in writing. Responsibility lies with customers and any experts or consultants involved in design and/or installation.
- Where applicable, this manual should be read in conjunction with manufacturer documentation for any components specified in the installation requirements of this manual.
- Where necessary, refer to the Sunamp website (www.sunamp.com) for contact and support information.

1.3 Mechanical Safety

⚠️ WARNING

- DO NOT install outdoors. This product is only suitable for indoor use only to avoid weather damage.
- DO NOT tilt the product more than **45 degrees** during the transportation or installation process.
- Install the product on a **hard, solid and level surface** that can support its weight.
- DO NOT use **detachable hose-sets** to connect the system to water mains.

- All hot works (such as soldering, welding or brazing) must be performed on tubes detached from the heat battery (minimum 1 metre away).
- This product is NOT suitable for tank fed hot water system.
- Do not immerse this product in water or any other liquid.

1.4 Electrical Safety

⚠WARNING

- The product must be earthed correctly and have its own independent electrical supply (with correct voltage and circuit breakers).
- The point of connection to the mains should be readily accessible and adjacent to the Heat Battery installation.
- Connection must allow isolation of the electrical supply. The means of isolation must be accessible to the end user after installation.
- Disconnection must be achieved by a **fused spur** in accordance with the wiring rules.
- Ensure that there is water in the appliance before switching on electrical supply.
- All models in this manual are designed for heating by using a Low Temperature Heat Pump and as a backup by using an integrated electric heater.

1.5 Water Safety

⚠WARNING

- **Minimum** working pressure of Heat Battery is **0.15 MPa / 1.5 Bar**. **Maximum** working pressure of Heat Battery is **1.0 MPa / 10 Bar**. See section 2.5.2 for detailed specifications.

Sunamp

1.6 User Competence, Qualification, and Approval

⚠WARNING

- ONLY competent persons who are suitably qualified to carry out plumbing and electrical work and have successfully completed product training by Sunamp Ltd or an authorised training partner may undertake installations, repairs or relocations.
- DO NOT allow children or any other unqualified or unapproved persons to install, repair, clean, relocate, interfere or tamper with the product.
- This product is not designed for use by children, or persons with reduced physical, sensory or mental capabilities, and should not be used by such persons unless they can do so safely. Where necessary, such persons (or anyone with lack of experience or knowledge) should first be given supervision or instruction concerning use of the product by a person responsible for their safety.

1.7 Compliance with Safety Laws and Regulations

⚠CAUTION

- Installations, repairs and relocations must comply with all relevant local laws and regulations ('statutory obligations'), particularly concerning electrics, water supplies, building regulations and Manual Handling Operations, as issued by the Government *Health and Safety Executive* ('HSE'). Water distribution and central heating installations ('systems') must comply with all statutory obligations.
- Statutory obligations always override manufacturer documentation where there is a conflict.

1.8 Post-Installation Safety

- All goods are sold subject to Sunamp Ltd's 'Conditions of Sale', as listed on our website.

- As Sunamp Ltd continuously improves products, they may be modified without notice. In such circumstances this manual and other relevant documentation should be disregarded. Updated documentation will be produced, supplied with new product ranges and made available on request.
- Once installed:
 - Perform a test run to ensure normal operation.
 - Explain all safety precautions to the end user.
 - Provide a copy of this manual to the end user.
- It is the responsibility of the end user to supply this manual to any other subsequent users.

1.9 Repair and Relocation

⚠WARNING

- DO NOT attempt to carry out repairs or maintenance before the system components – including the **UniQ HW +iLTHP Heat Batteries** - have cooled down to ambient room temperature. To speed up the process, disconnect power supply and open hot water taps in the dwelling to draw off hot water and cool system down.
- DO NOT attempt to move an assembled system without using appropriate lifting equipment.
- There are no user serviceable, adjustable or settable parts in this product.

**SAVE THESE INSTRUCTIONS AND
PROVIDE A COPY TO THE END USER.**

2 UniQ HW +iLTHP Heat Battery Overview

2.1 Introduction

Thank you for choosing a Sunamp Ltd UniQ Heat Battery, our innovative, super-compact heat storage systems based on phase-change materials (PCM). We are sure you will be delighted with the performance, compactness, ease of installation and quality of our product.

Sunamp Ltd's decade-long history of research and innovation in PCM technology has made it the world-leading manufacturer in Heat Battery technology – developed, designed and manufactured in the UK.

Sunamp Ltd has a wide portfolio of Heat Batteries for different applications. Please visit our website (www.sunamp.com) or look at our catalogue for more information about our portfolio for:

- Water heating
- Space-heating
- Combined space- and water-heating
- Cooling

The Sunamp Ltd **UniQ HW +iLTHP** Heat Batteries are:

- Designed to produce domestic hot water heating by using a Low Temperature Heat Pump as a main source of heat, the range of heat batteries have a standby heating element built in to act as a backup if the main heat source fails.
- Equivalent to indirectly heated hot water cylinders and hot water only thermal stores.
- Able to replace indirect vented and unvented hot water cylinders for heat pumps.
- Classified as a *Primary* Thermal store. By transferring heat from the PCM to the mains water flowing through the heat exchanger, they produce hot water instantaneously and on demand.
- Class I stationary appliances that use a single-phase electrical supply.



See the [downloads section](#) of our website (www.sunamp.com) for other useful information on Sunamp Ltd. products.

2.2 Product Overview

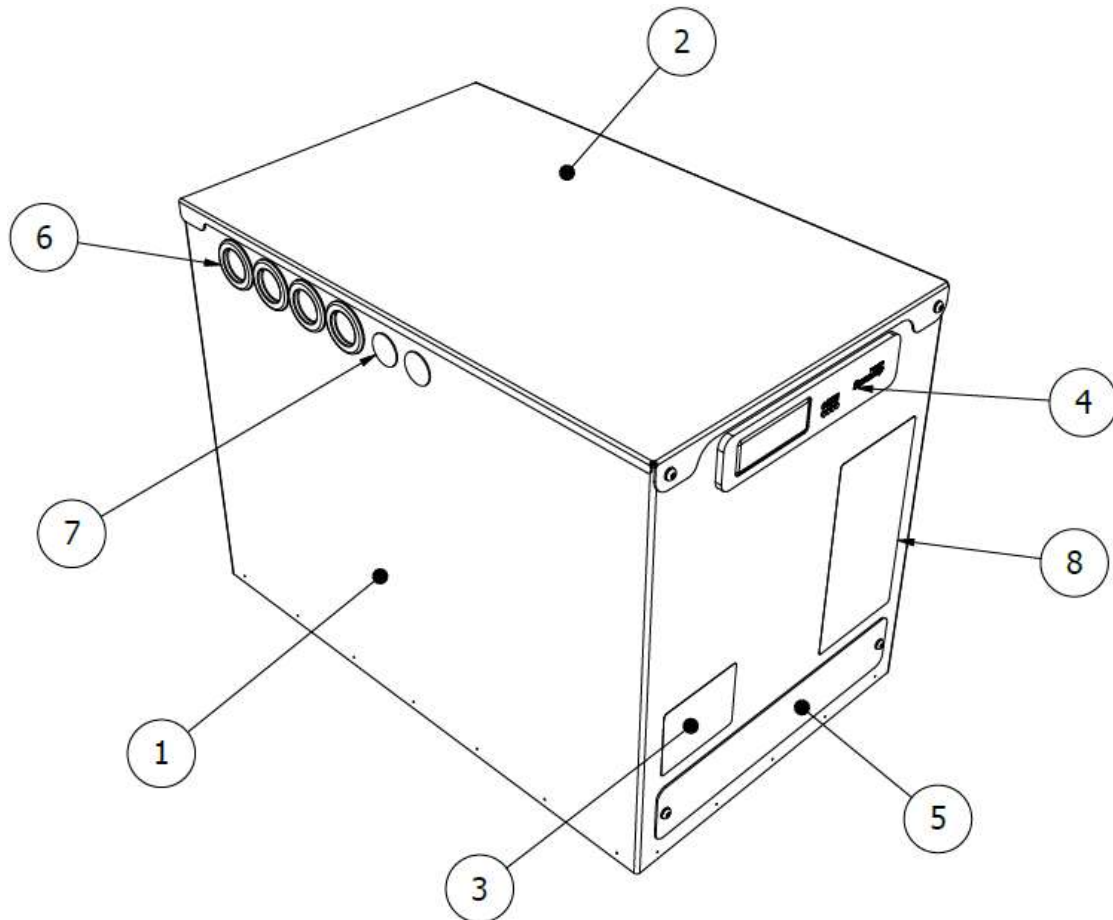

Figure 1: Heat Battery (external)

Item	Description
1	Heat Battery – main body
2	Heat Battery – lid
3	Data badge / serial number
4	Controller interface
5	Terminal cover plate
6	Tube entries (3 sides)
7	Cable entries (3 sides)
8	Energy label – to be applied by installer (if applicable)

Table 1: Product overview (external)

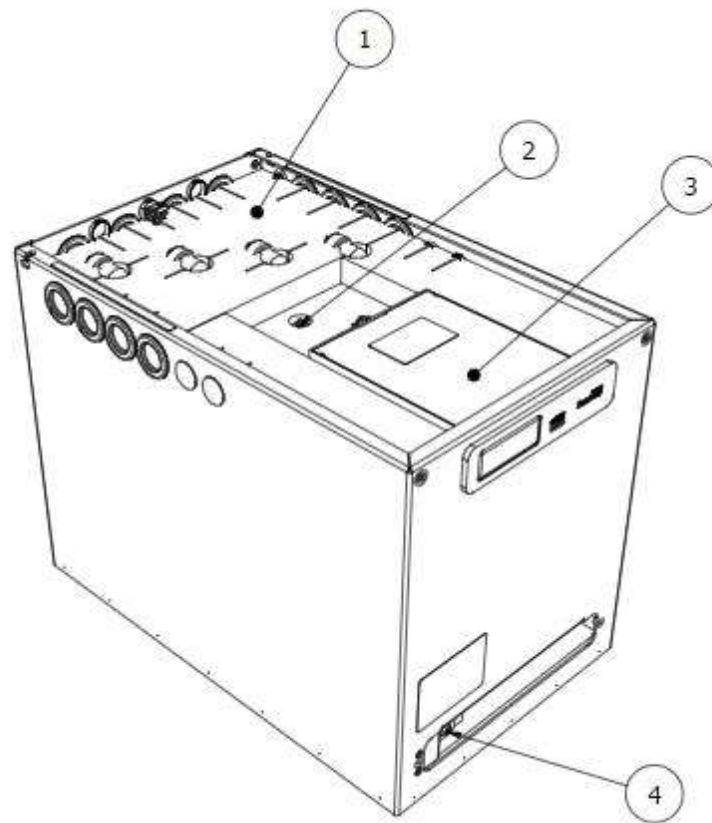

Figure 2: Heat Battery (internal)

Item	Description
1	Insulation layers – to be cut to suit copper tube and cable entries
2	Temperature sensor
3	Electrical control box – PCB, relays, terminal block
4	Non-self-resetting overhear thermostat (OHT)

Table 2: Product overview (internal)

2.3 Product Identification

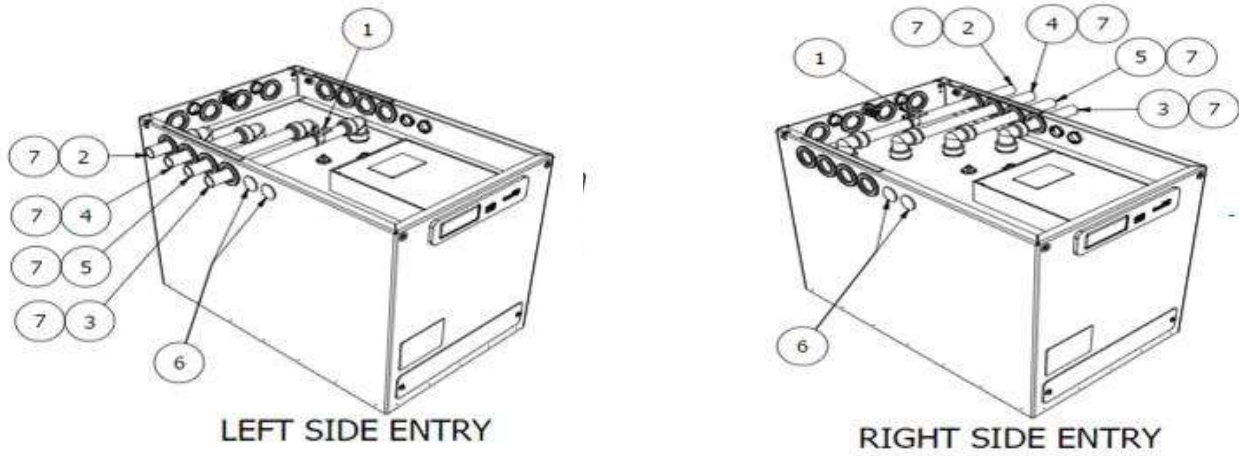

Figure 3: Heat Battery views showing the three tube exits

Item	Description	Item	Description
1	Earth Clamp (supplied) - to be clamped to Ø22mm copper tube	5	Heat Pump Flow – “C” – Ø22mm elbow – rotatable 360 degrees
2	Cold Water Inlet – ‘A’ – Ø22mm elbow – rotatable 360 degree	6	Cable Entry via Gland - supplied but not fitted
3	Hot Water Outlet – ‘D’ - Ø22mm elbow – rotatable 360 degrees	7	Ø22mm Copper Tube to BSEN1057 - suitable for installation (not supplied).
4	Heat Pump Return – “B” – Ø22mm elbow – rotatable 360 degrees		Tube and cable entries are used depending on installation location

Table 3: Product installation options

2.3.1 LED Interface

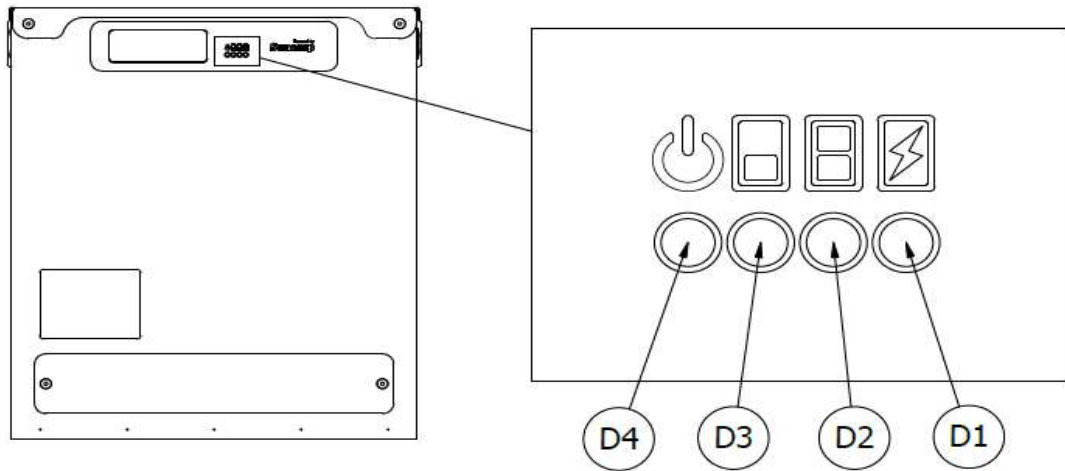

Figure 4: LED interface

Item	Description
D4	Mains power LED
D3	Charge level status LED
D2	Charge level status LED
D1	Heater 'Active' LED

Table 4: LED interface

2.4 Accessories and Parts

Part Number	Description
C5388	Thermostatic Mixing Valve (TMV)
C5034	Expansion Vessel 0.5L
C5381	Water conditioner
C5377	22mm Tectite Pro Elbow TX12 65524 (see note)
C5379	22mm Tectite Pro Tee TX24 65676
C5412	Conex BM8090 0220000 22mm >B<Push elbow

Table 5: Accessories.



Note: 4 x C5377/C5412 are supplied with the product as standard. Visit our website (www.sunamp.com) for all the latest accessories and spare parts.

2.5 Technical Specifications

2.5.1 Basic Specifications

Battery Model	Height (mm)	Depth (mm)	Length (mm)	Gross Weight (kg)	Net Weight (kg)
UniQ HW 3 +iLTHP	429	365	575	74	70
UniQ HW 6 +iLTHP	630			132	125
UniQ HW 9 +iLTHP	856			185	175
UniQ HW 12 +iLTHP	1070			234	220

Table 6: UniQ HW +iLTHP Heat Battery models. **Net Weight** refers to an **empty Heat Battery** (i.e. no water in the tubes); **Gross Weight** refers to being filled with water.

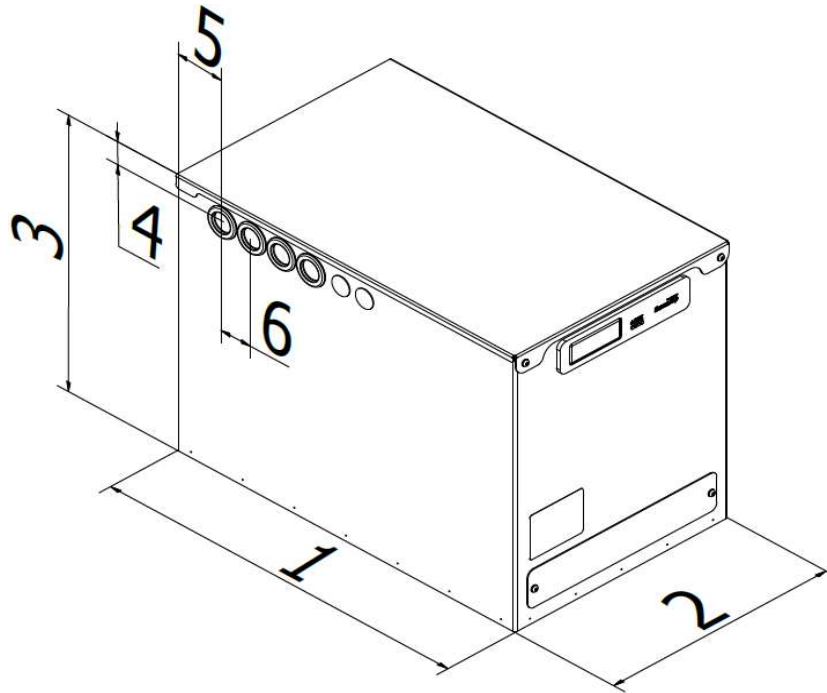

Figure 5: Additional Sunamp Ltd **UniQ HW +iLTHP** Heat Battery dimensions

Item	Description	Item	Description
1	Length: See Table 6	4	37mm
2	Depth: See Table 6	5	78mm
3	Height: See Table 6	6	50mm

Table 7: Additional product dimensions

2.5.2 Detailed Specifications

Specification	Size 3	Size 6	Size 9	Size 12	See Note
Heat Storage Capacity (kWh)	3.2	6.3	9.5	12.6	1
Water Content (L)	LPC (C→B)	2.4	3.5	4.6	2
	HPC (A→D)	4.5	6.8	9.1	
	Combined	6.9	10.3	13.7	
Equivalent Hot Water Cylinder Size (L)	65	128	192	256	3
V ₄₀ , Volume of Hot water available at 40°C (L)	78	167	271	333	4
Standby heat loss rate (kWh / 24h (W))	0.48 / (20)	0.67 / (28.1)	0.77 / (32.1)	0.84 / (34.9)	
ErP Rating class	A+				6
Recommended maximum HW flow rate (L/Min)	6	15	20	25	
Minimum heat source flow temperature (°C)	65				7
Maximum heat source flow temperature (°C)	80				8
Minimum mains supply pressure at inlet of Heat Battery (MPa / (Bar))	0.15 / (1.5)				
Maximum working pressure (MPa / (Bar))	1.0 (10)				
Pressure loss characteristics K _v Values	Figure 6.1 & 6.2 (Section 2.6)				
Hot water outlet temperature at design flow rate (°C)	45-55				5
Connected load at ~ 230 V, 50Hz (W)	2,800				
Power supply / Standby consumption (W)	1 PH ~ 230 V / 7				

Table 8: Detailed specifications for UniQ HW +iLTHP Heat Battery models



Notes to Table 8:

1. Heat Battery charged to design charge temperature by a Low Temperature Heat Pump T_C (64°C-66°C) and then discharged using inlet discharge water temperature T_D (10°C) until the outlet water temperature dropped to 40°C.
2. Water content of the Heat Battery for sizing expansion vessels.
3. Calculated from the storage capacity of the Heat Battery and assuming that the hot water cylinder thermostat is set at 60°C, mains cold water inlet temperature is at 10°C and the stored energy calculated from the storage capacity of the Heat Battery and assuming that the hot water outlet temperature is set at 40°C, mains cold water inlet temperature is at 10°C and the stored hot water utilisation factor for cylinder is 0.95.
4. The hot water volume available from the Heat Battery at average outlet temperature of 40°C when it is charged to 75°C, tested to standards:
 - BS EN 12897:2016+A1:2020 Water Supply. Specification for indirectly heated unvented (closed) storage water heaters.
 - BS EN 60379-2004 Methods for measuring the performance of electric storage water-heaters for household purposes.
5. Recommended setting range for hot water thermostatic mixing valve.
6. When heated by an external heat source.
7. Minimum constant heat source flow temperature from an external heat source for charging the Heat Battery.
8. Heat source flow temperature should not exceed this value when the Heat Battery is being charged.



For more detailed specifications, also see the **UniQ Heat Batteries General Product Application and Design Manual**, available from the [downloads section](#) of our website (www.sunamp.com).

2.6 Pressure Loss Characteristics

The primary circuit ports C & B of the heat battery are connected to the heat pump flow and return as shown schematically in (Figure 6.3). The primary circuit design flow rate will depend upon the thermal rating of the heat pump and the design temperature difference. For a typical system, the primary flow rates are given in (Table 9),

Thermal output of the heat pump (kW)	4.0	6.0	8.0	10.0
Primary flow rate at 5°C design temperature difference (l/min)	11.4	17.4	22.8	28.8

Table 9: UniQ HW +iLTHP Heat Battery Primary circuit flow rate

The corresponding values for the pressure loss through the primary heat pump circuit can be read in (Figure 6.2).

The secondary ports A & D of the heat battery are connected to dwelling hot water circuit as shown schematically in (Figure 6.3). The pressure loss values can be read in (Figure 6.1).

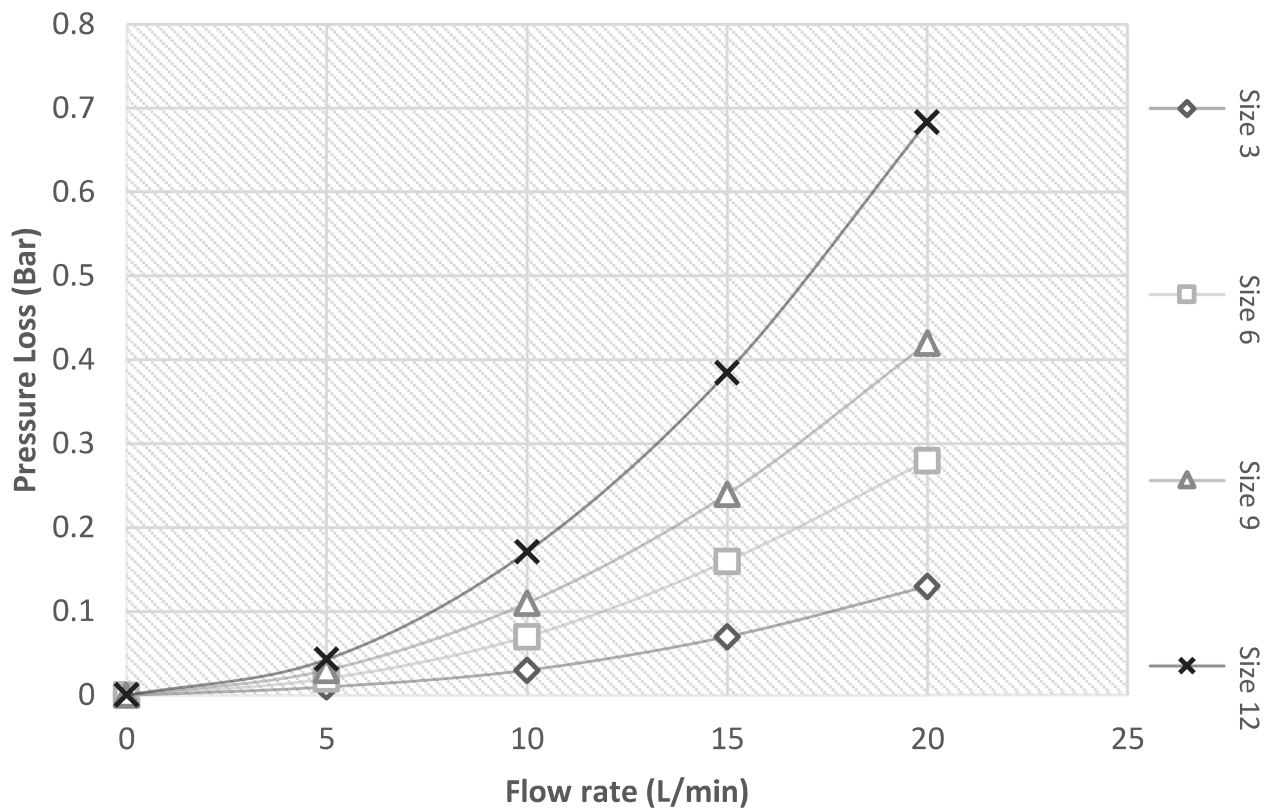

Figure 6.1: *UniQ HW +iLTHP* Heat Battery Secondary circuit pressure loss characteristics graph

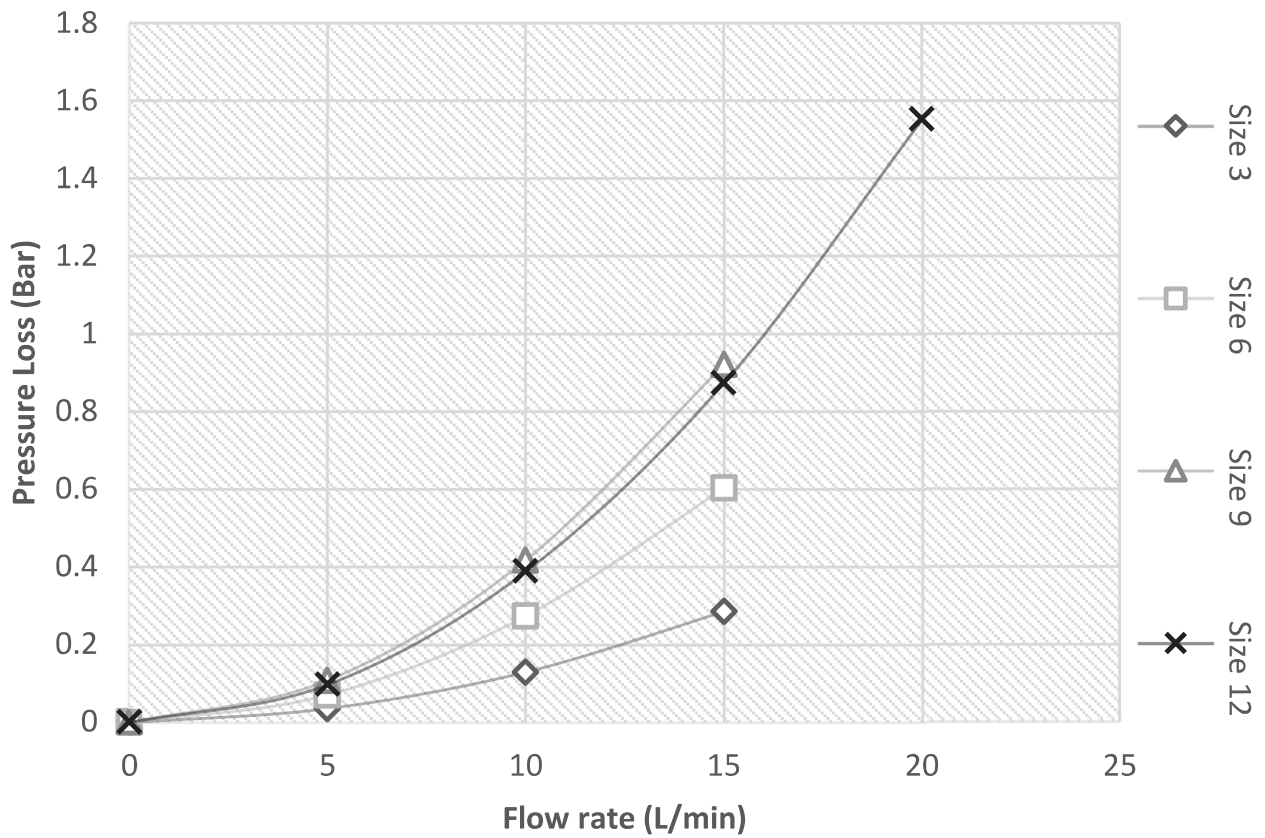

Figure 6.2: UniQ HW +iLTHP Heat Battery Primary circuit pressure loss characteristics graph

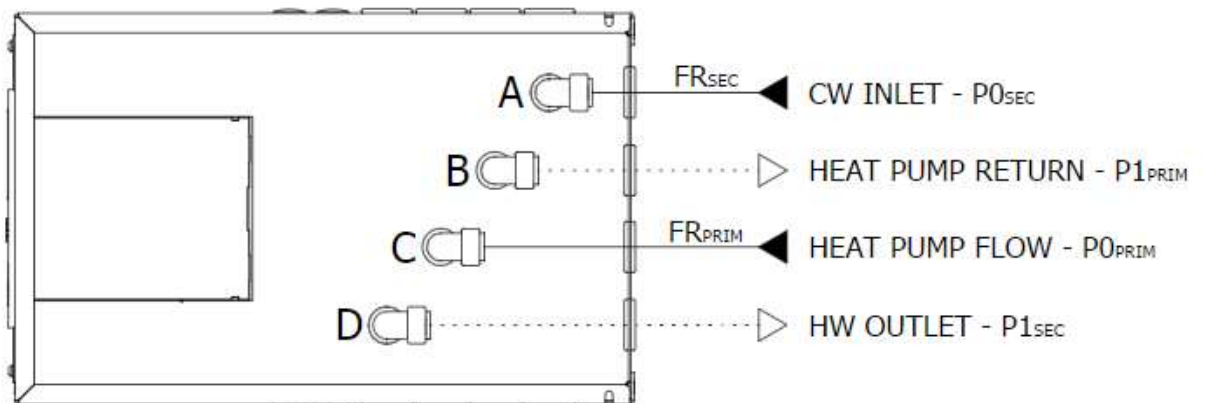

Figure 6.3: Pressure loss at inlet & outlet of the Heat Battery

3 Installation



Always read the safety instructions in Section 1 of the manual before installing **UniQ HW +iLTHP** Heat Batteries.

3.1 Installation Process

Preparation:

- Assess the location of installation considering spatial requirements, clearances, cable runs and tube runs.
- Unpack and discard or recycle packaging according to local disposal or recycling rules.
- Identify which side you wish to make hydraulic and electrical cable entries (see Figure 3 in Section 2.3).
- Prepare the system hydraulics and electrics.
- Lift unit into position using appropriate lifting methods.

Hydraulic Connection:



Note: The mains cold water inlet connects to port A; Hot water outlet connects to port D. Meanwhile the LTHP flow pipe connects to Port C and the LTHP return pipe connects to Port B (Figure 6.3).

- Remove lid. The lid is secured by 2 x M5 button head capscrews at the front and two locating pins at the back (Figure 7):
 - Remove 2 x M5 button head capscrews using 3mm hex head and set aside.
 - Slide the lid forward, then lift the lid up and set aside.
- Remove the top two layers of insulation (layer 1 is 10mm and layer 2 is 32mm thick) and set aside.
- Rotate the elbows to the side you wish to connect the hydraulics (left, right or back).
- Remove the respective rubber grommets in the outer housing and cut the centres (with a cross) with a knife. Re-insert the cut grommets.
- Cut and prepare the two off lengths of Ø22mm copper tube to suit the rest of the installation / system:
 - Always cut the tube square, using a rotary tube cutter whenever possible. Ensure the cutter wheel is appropriate for the copper tube.

- Deburr the tube end, both internally and externally to create a 1mm chamfer on the outside of the tube.
 - Check the tube ends are free from damage and clean, wiping away any swarf to avoid damaging the 'O' ring on tube insertion.
 - Tube end must also be free from stickers, tape and adhesive residues.
 - Mark the socket depth (27mm) on the tube with a marker.
 - Insert the tube firmly with a slight twisting action until it reaches the tube stop with a positive "click".
 - Ensure the depth insertion mark corresponds with the mouth of the fitting, then pull firmly on the tube to ensure the fitting is secure.
- Fit the earth clamp to the Ø22mm copper tube (See Figure 3 in Section 2.3).
 - Connect to the rest of the fixed system hydraulics.
 - Fill the system with water, purging any air out of the system. This may take several minutes and can be aided by repeatedly opening and closing the outlet.
 - Once finished purging and with the system pressurised, inspect the piping/tubing and joints for any leaks. Take remedial action if necessary.



Electrical Connections:

- Move the cable strain relief fittings to the side you wish to make the entries / exits. Cover all other holes in the enclosure with the supplied blanking grommets. (Figure 8).
- Feed the mains cable through the strain relief bushing in the heat battery housing.
- If applicable, feed the signal cable through the additional strain relief fittings.
- Line up the cable strain relief fitting ratchet feature and compress firmly so that the fitting grips the cable.
- Open the internal controller enclosure using a flat head screwdriver to remove the snap in' lid.
- Connect the wires according to the wiring options if not already fitted.
- Remove or make links according to the wiring options.

- Close up the internal controller enclosure replacing the 'snap fit' lid and check the earth clamp on the copper tube is secure.

Final Fit After Commissioning:



Commissioning instructions are provided in Section 4 of this manual. Follow the instructions below after commissioning.

- Cut the 32mm thick insulation layer to suit the tube and cable entries. This layer has several perforations for guidance. This can be done with a sharp knife or scissors.
- Replace the newly cut 32mm thick insulation layer nesting the insulation around the tube work and cables. Make sure the mains and signal cables sit above this layer.
- Replace the top layer 10mm layer of insulation.
- Replace the lid, aligning the rear pins with the slots in the rear of the unit, slide back, fit the 2 x M5 button head capscrews using 3mm hex head.

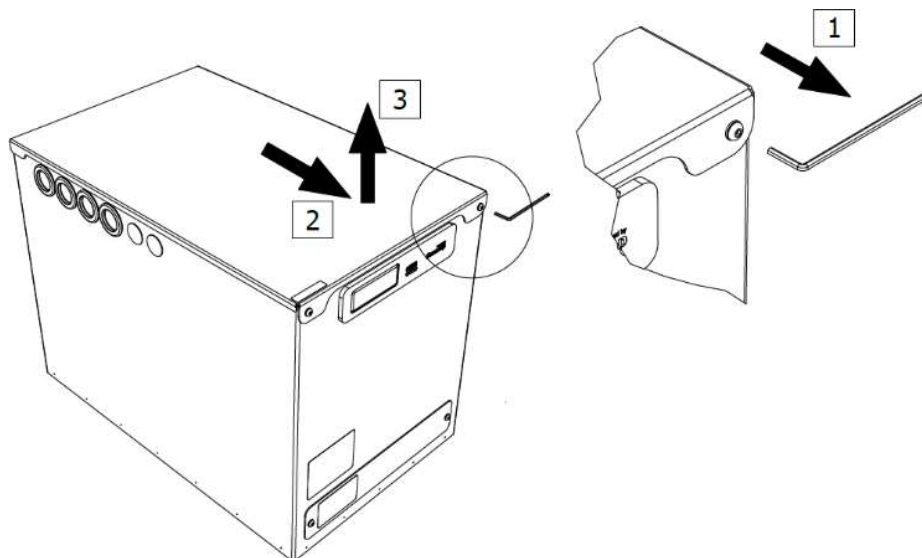

Figure 7: Access to Heat Battery connections

Item	Description
1	Remove fasteners x2 using 3mm Allen Key
2	Slide lid forward
3	Lift lid

Table 9: Access to Heat Battery connections

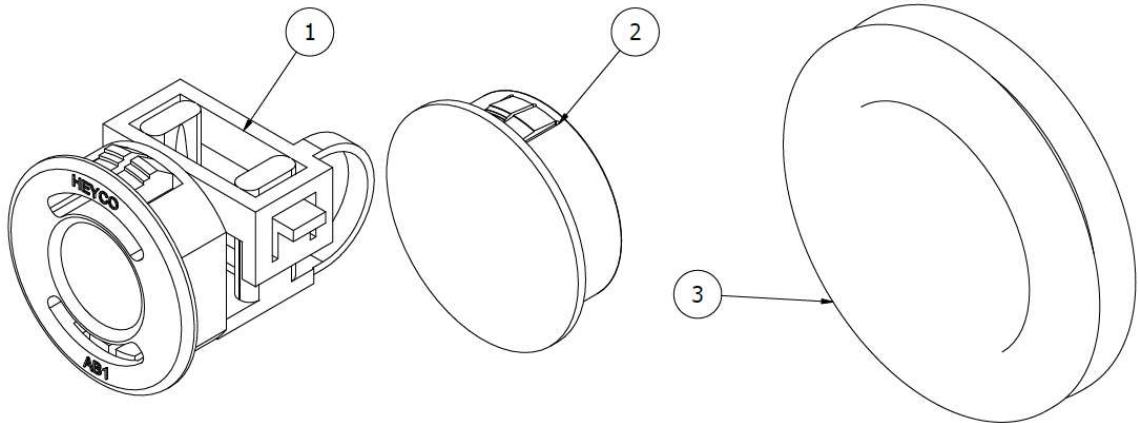

Figure 8: Cable and tube interfaces

Item	Description
1	Cable entry strain relief gland
2	Cable entry blanking bush
3	Tube entry grommet

Table 10: Cable and tube interfaces

3.2 Water Supply Requirements



Important: All components fitted in the water system should be *Water Regulations Advisory Scheme (WRAS)* approved.

3.2.1 General



For information regarding expansion vessel sizing and pressure relief valves, refer to the **UniQ Heat Batteries Reference Manual**, available from the [downloads section](#) of our website (www.sunamp.com).



Important: Although the Heat Batteries are designed for **1.0MPa (10 bar)** maximum working pressure, it is recommended that if the incoming mains pressure is greater than **0.5MPa (5 bar)**, a WRAS approved pressure regulator set at 0.5MPa (5 bar) should be fitted.

- Mains cold water supply should be connected to Heat Battery connection 'A'. The hot water outlet should be connected to 'D'. Heat Pump Flow should be connected to Heat Battery connection 'C' and Heat Pump Return should be connected to Heat Battery connection 'B'. (see Figures 8, 11.1 and 12.1).
- DO NOT use detachable hose-sets to connect the product to the water mains.
- Minimum - Maximum dynamic mains water supply pressure: **0.15MPa (1.5bar) - 1.0MPa (10 bar)**.
- Minimum mains cold and hot water tube sizes: **Ø22mm copper or equivalent**.
- Expansion vessel charge pressure = Incoming mains pressure (MPa).
- A potable water expansion relief valve is only required when the water cannot expand back into the mains (e.g. where a non-return valve is fitted).
 - In these occasions, to protect against a failure of the expansion vessel, a potable water expansion relief valve should be fitted.
 - Its setting will depend upon the mains water pressure: **1MPa (10 bar)**. The valve should be fitted in compliance with Building Regulations Approved Document G.
- The heat pump circuit (closed circuit) must be fitted with an expansion relief valve.
- A WRAS approved hot water thermostatic blending valve should be fitted at the outlet from the heat battery. The blending valve should be set to deliver hot water between 45°C and 55°C.

3.2.2 Hard Water and Limescale



Where mains water hardness can exceed **150 ppm Total Hardness**, you must install a scale reducing device in the cold-water supply to the Heat Batteries.

Limescale can be controlled using: chemical limescale inhibitors, polyphosphate dosing, electrolytic scale reducers or water softeners.

3.3 Location and Space Requirements

- The Heat Battery is suitable for indoor use only.
- Avoid locations in close proximity to other building services, hot works, and other sources of heat. Hot works, such as soldering, welding or brazing must **ONLY** be undertaken a **minimum distance of 1m from the system** and by using cooling clips or other heat absorbent materials.
- Due to the weight of the Heat Battery, ensure the floor is level, sound and capable of supporting its weight (Table 6).
- Allow for space of 150mm around the Heat battery (i.e. to view LED lights), and space of 450mm above it (i.e. to remove the lid if necessary):

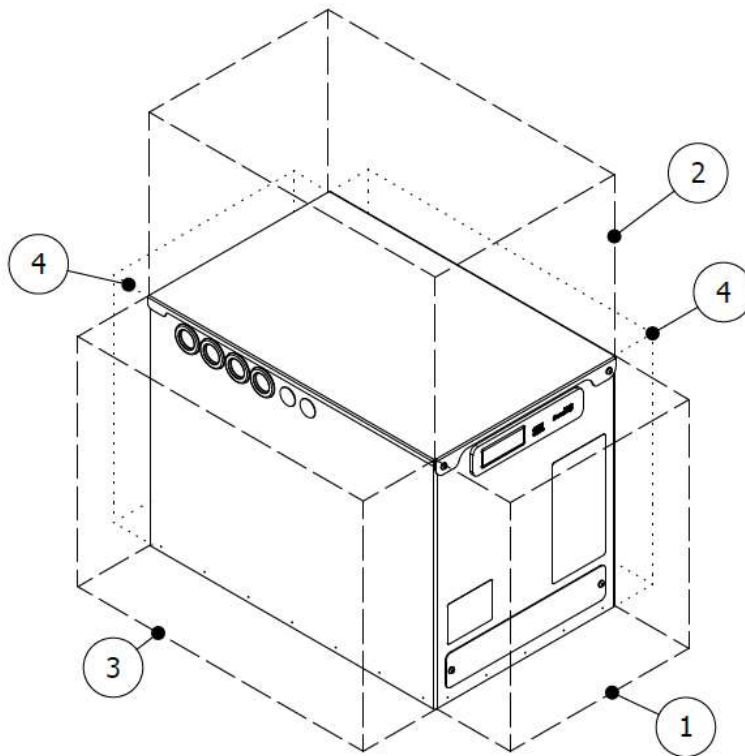

Figure 9: Spacing (in mm) surrounding the Sunamp Ltd. Heat Battery

Item	Space	Reason
1	150mm	To access terminal cover and to ensure visibility of the data badge and LEDs
2	450mm	To remove lid and access internals
3	150mm	To allow for tube and cables entry (side dependent)
4	10mm	If no access required (side dependent)
-	< 3000mm	Recommended length of cable runs

Table 11: Space requirements

3.4 Hydraulic Requirements



Sunamp Ltd. Heat Batteries are NOT suitable for tank-fed hot water systems.

- All connection tube work inside the Heat Battery casing must be **Ø 22mm copper tube**. This to allow the earth connection between the case, inlet, and outlet tube fittings.
- Ensure that the unit is **electrically isolated** from mains and that the controller lid is closed whilst performing any hydraulic pipework. This is to avoid water or particles coming into contact with the PCB and other electrical components.
- DO NOT fit Isolation valves between the expansion vessel and the Heat Battery.
- The tube grommets used for inlet and outlet into the Heat Battery must be cut to allow the passage of the copper tubes by safely using an appropriate cutting tool.
- Although Ø22mm copper or equivalent plastic tube work should suffice in most installations:
 - Plastic tube work must not be used inside the heat battery and no plastic tube connections must be made to the heat battery inlet or outlet ports.
 - It is recommended that sizing of the tube work should consider mains water supply pressure, the design flow rates, size of the Heat Battery and pressure loss.
- As a mandatory requirement it is necessary to install an energy supply cut off valve or equivalent (i.e. 2-way port valve or 3-way port valve) on the Heat Pump Flow circuit.



3.5 Temperature and Insulation Requirements



Applying excessive heat to the system tubes will cause damage to the Heat Battery and its internal components.

- Heat Batteries use the SU58 Phase-Change Material (PCM), which has a **phase transition temperature of 58°C**.
- All connected tubes should be insulated for **at least 1m** from their connection points with the Heat Battery.
- The flow temperature of the Heat Pump must not exceed 80°C.

3.6 Electrical and Wiring Requirements

All range models within this manual are fitted with an internal controller situated at the top of the Heat Battery. Two wiring options are available:

1. **+iLTHP option 1:** Samsung Low Temperature Heat Pump
2. **+iLTHP option 2:** Daikin Low Temperature Heat Pump

Regardless of the option chosen, the Heat Battery is charged by the Heat Pump from top to bottom and discharges hot water draw-off from top to bottom. When operating in a backup mode the heating element charges the Heat Battery from bottom to top.

Additionally, the Heat Battery does NOT require a separate control circuit electricity supply which is supplied internally by a main heating system power supply.

3.6.1 General



External wiring to the Heat Batteries must be in accordance with current IET (BS.7671) Wiring Regulations and any other applicable local regulations. Local **Means for disconnection must be incorporated in the fixed wiring in accordance with the wiring rules.**



Note: The lid cover of the controller can be removed by using a flat head screwdriver.

- The Heat Batteries must be earthed correctly.
- The point of connection to the mains should be readily accessible and adjacent to the Heat Battery installation; a fused spur is required.
- The product must have its own **dedicated 16A MCB protected** supply.
- Connection must allow isolation of the electrical supply, such as a double pole switch having a 3mm (1/8") contact separation in both poles. The means of isolation must be accessible to the end user after installation.
- All models are designed with an integrated electric heater. Install in accordance with the instructions provided (3.7 & 3.8).
- All models are fitted with only one 2.8kW heating element at ~230V AC and therefore recharging times increase with size of the Heat Battery when using the heating backup mode.
- The mains power cable to the Sunamp Controller should be a minimum of 2.5mm², 3 core HO5 VV-F sheathed cable, to BS 6500. This cable must be prepared according to Figure 10 (below), were the Green/

Yellow (Protective Earth) wire is 15 mm than the Brown (Live) and Blue (Neutral) wires.

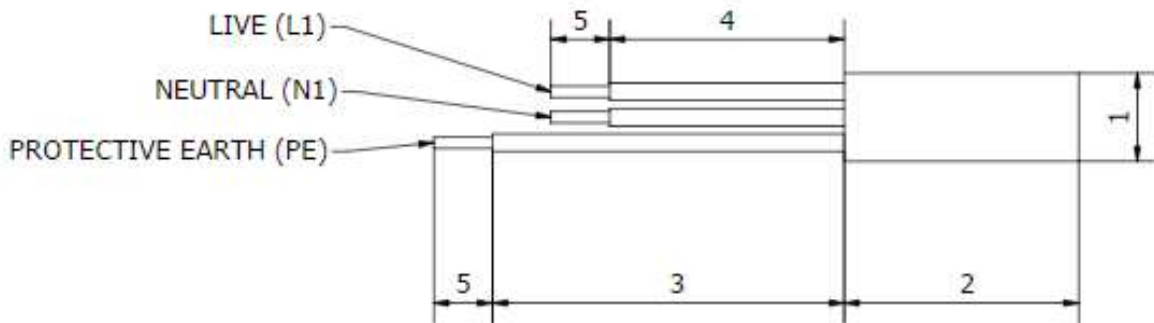

Figure 10: Wire length preparation diagram

Item	Description
L1	Live
N1	Neutral
PE	Protective Earth
1	Ø10.5mm MAX
2	< 3000mm
3	65mm
4	50mm
5	8mm

Table 12: Wire lengths

3.6.2 Controller Wiring Diagram

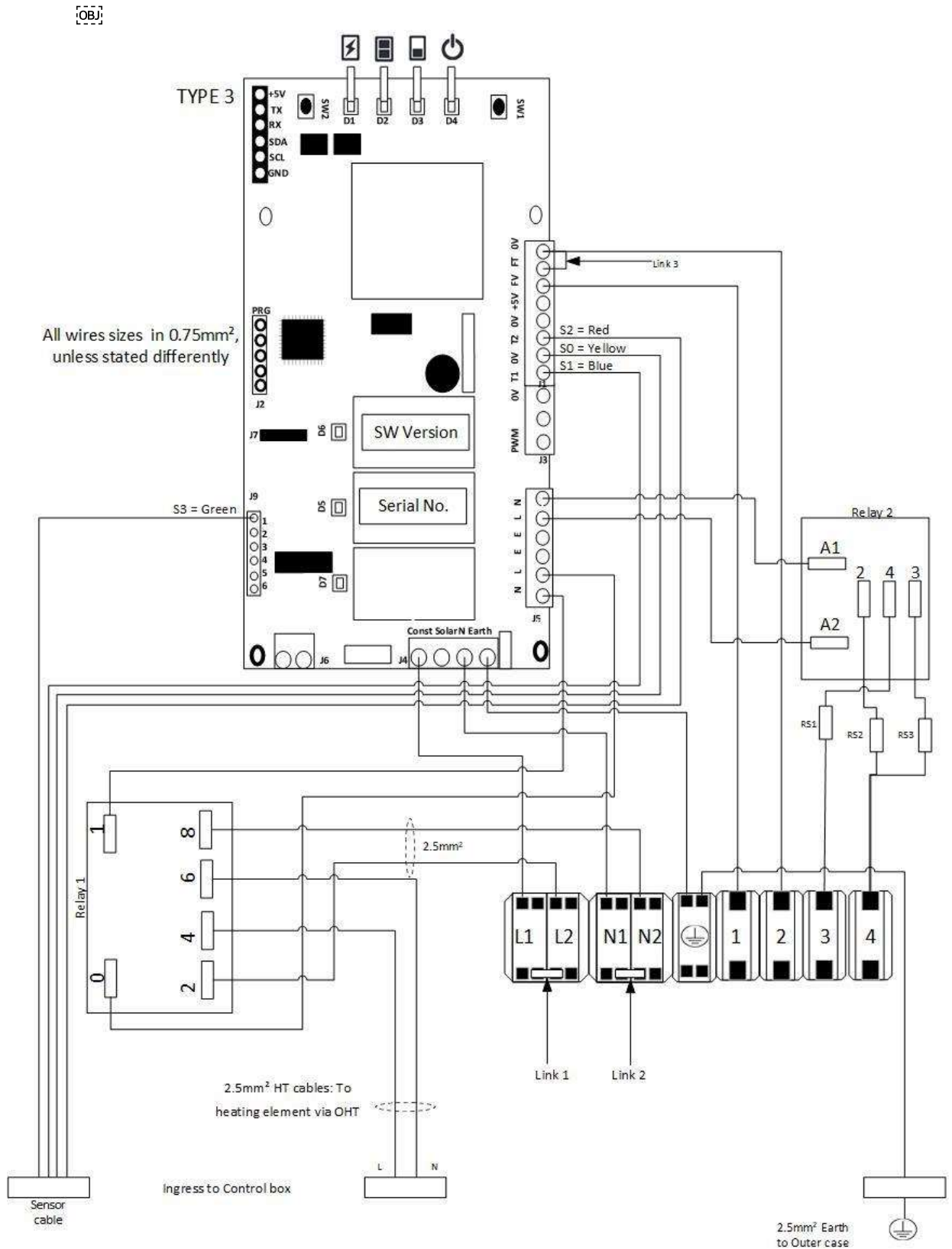

Figure 11: Internal controller wiring diagram (wire sizes=0.75mm², unless stated otherwise)

3.7 Wiring Option 1 – HW +iLTHP Samsung Low Temperature Heat Pump



Important: Please follow (Table 13.1) for information regarding the Links.

Link specification	Removed or Fixed
Link 1	Fixed
Link 2	Fixed

Table 13.1: Wiring Option 1 – Link settings

- Run and connect 3 Core mains power supply cable (16A, minimum 2.5mm² CSA) from the local 2-pole isolator to the Heat Battery controller (Figures 12.1 and 12.2).
- Wire the cable via the appliance case grommets and into the control box housing (Figures 8,12.1 and 12.2).
- Prepare the wire if necessary according to (Figure 10) and wire the mains power cable in the following terminals (Figure 12.2):
 - **Brown (Live):** Terminal L1 (Live)
 - **Blue (Neutral):** Terminal N1 (Neutral)
 - **Green/Yellow (Earth):** Terminal PE (Protective Earth)

3.7.1 Electric Override Switch

- Wire a 2 core PVC insulated cable (minimum 0.75mm² CSA, 24 x 0.2mm according to BS 6500) from a local 2-pole switch, run the wire into the appliance via the appliance case cabling grommets and then into the control box housing through the hole available. Secure the cables in Terminal T1 & T2 independently (Figure 12.2).



Note: Engaging this switch will put the Heat Battery into electric charging mode only. This can lead to increased electricity consumption, resulting in higher energy costs. This should be explained to the end user and the switch labelled accordingly.

3.7.2 Heat Pump Control Signal

- Wire a 2 core PVC insulated cable (minimum 0.75mm² CSA, 24 x 0.2mm according to BS 6500) from the Heat Pump Controller 2-pin connector labelled “Water Tank” (please refer to Heat Pump manual),

then run the wire into the appliance via the appliance case cabling grommets and then into the control box housing through the hole available. Secure the cables in Terminals T3 & T4 independently (Figure 12.2).

3.7.3 Controller Wiring Schematic and Diagram

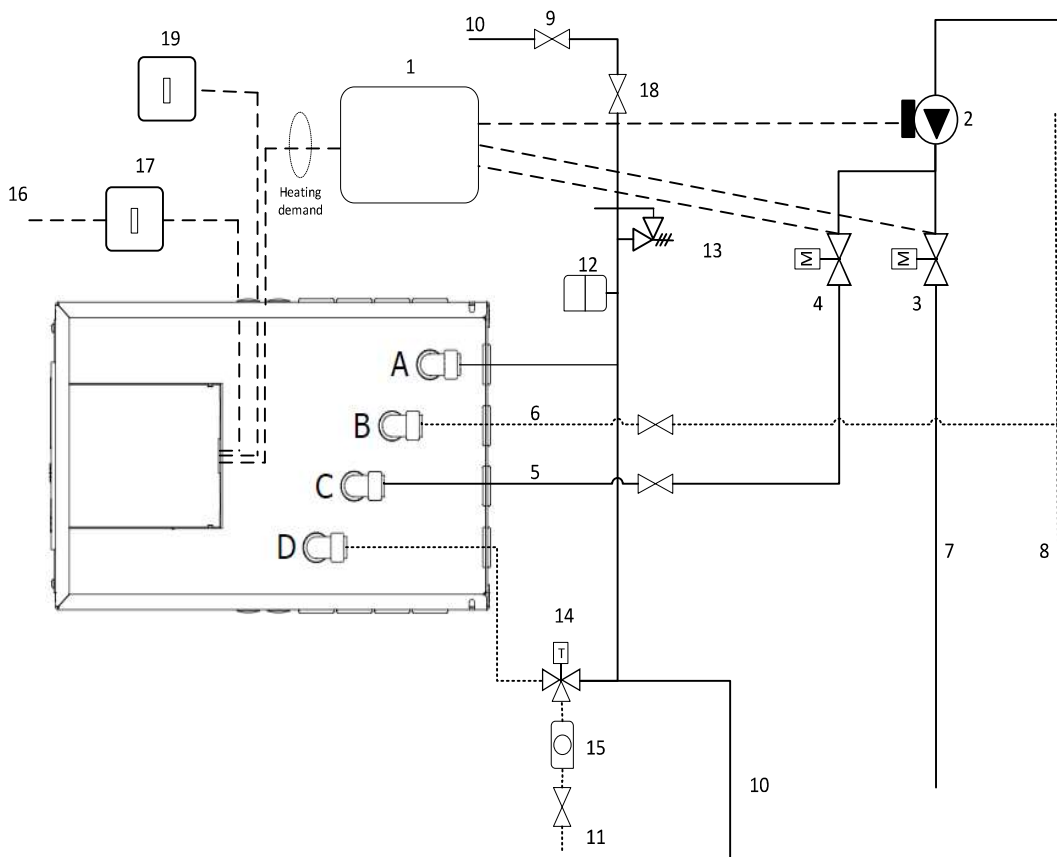

Figure 12.1: Example Wiring Option 1 Schematic (see Figure 3 for piping and electrical options available)

Item	Description				
1	Heat Pump Controller	7	Central Heating Flow	13	Mains Water Expansion Relief Valve
2	Circulation pump	8	Central Heating Return	14	Hot Water Thermostatic Blending Valve
3	Central heating Zone Valve	9	Check Valve	15	Hot Water flow regulator

4	Heat Battery Hot Water Zone Valve	10	Mains Cold Water Supply	16	230VAC 16A power supply
5	Flow from Heat Pump	11	Hot water to supply dwelling	17	Local 2-pole Isolator, 13A
6	Return to Heat Pump	12	Expansion Vessel	18	Cold Water Mains Pressure regulator
19	Electric override switch				

Table 13.2: Explanation of components

[OBJ:OBJ]

Figure 12.2: Wiring Option 1 diagram – HW +iLTHP Samsung Low Temperature Heat Pump

3.8 Wiring Option 2 – HW +iLTHP Daikin Low Temperature Heat Pump



Important: Please follow (Table 14.1) for information regarding the Links.

Link specification	Removed or Fixed
Link 1	Fixed
Link 2	Fixed

Table 14.1: Wiring option 2 – Link settings

- Run and connect 3 Core mains power supply cable (16A, minimum 2.5mm² CSA) from the local 2-pole isolator 13A to the Heat Battery controller (Figures 13.1 and 13.2).
- Wire the cable via the appliance case cabling grommets and then into the control box housing through the hole available (Figures 8, 12.1 and 12.2).

Sunamp

- Prepare if necessary, the mains power cable and wire in the following terminals (Figure 10):
 - **Brown (Live):** Terminal L1 (Live)
 - **Blue (Neutral):** Terminal N1 (Neutral)
 - **Green/Yellow (Earth):** Terminal PE (Protective Earth)

3.8.1 Electric override switch

- Wire a 2 core PVC insulated cable (minimum 0.75mm² CSA, 24 x 0.2mm according to BS 6500) from a local 2-pole switch, run the wire into the appliance via the appliance case cabling grommets and then into the control box housing through the hole available. Secure the cables in Terminal T1 & T2 independently (Figure 13.2).



Note: Engaging this switch will put the Heat Battery into electric charging mode only and disable the function of the Heat Pump until the switch is set to off. This can lead to increased electricity consumption, resulting in higher energy costs. This should be explained to the end user and the switch labelled accordingly.

3.8.2 Heat Pump sensor cable wiring

Wire a 2 core PVC insulated cable (3A, minimum 0.75mm² CSA, 24 x 0.2mm according to BS 6500) from the Heat Pump Indoor Tank sensor connection “X9A (PCB A1P)” (please refer to Heat Pump manual) , then run the wire into the appliance via the appliance case cabling grommets and then into the control box housing through the hole available. Secure the cables in Terminals T3 & T4 independently (Figure 13.2).

3.8.3 Controller Wiring Schematic and Diagram

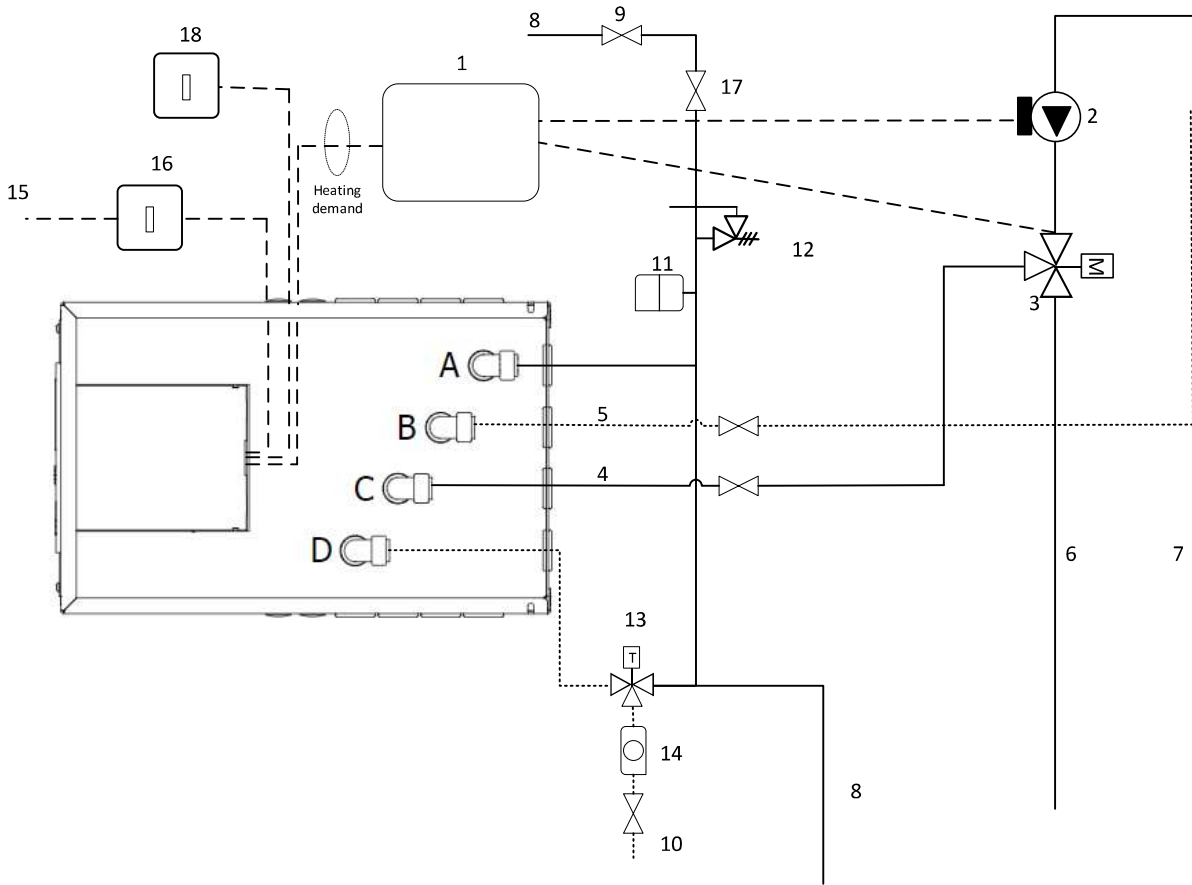

Figure 13.1: Example Wiring Option 2 Schematic (see Figure 3 for piping and electrical options available)

Item	Description				
1)	Heat Pump Controller	7	Central Heating Return	13	Hot Water Thermostatic Blending Valve
2	Circulation pump	8	Mains Cold Water Supply	14	Hot Water flow regulator
3	Motorised Three port Valve	9	Check Valve	15	230VAC 16 A power supply
4	Flow from Heat Pump	10	Hot water supply to dwelling	16	Local 2-pole isolator, 13A

5	Return to Heat Pump	11	Expansion Vessel	17	Cold Water Mains Pressure regulator
6	Central Heating Flow	12	Mains Water Expansion Relief Valve	18	Electric override switch

Table 14.2: Explanation of components

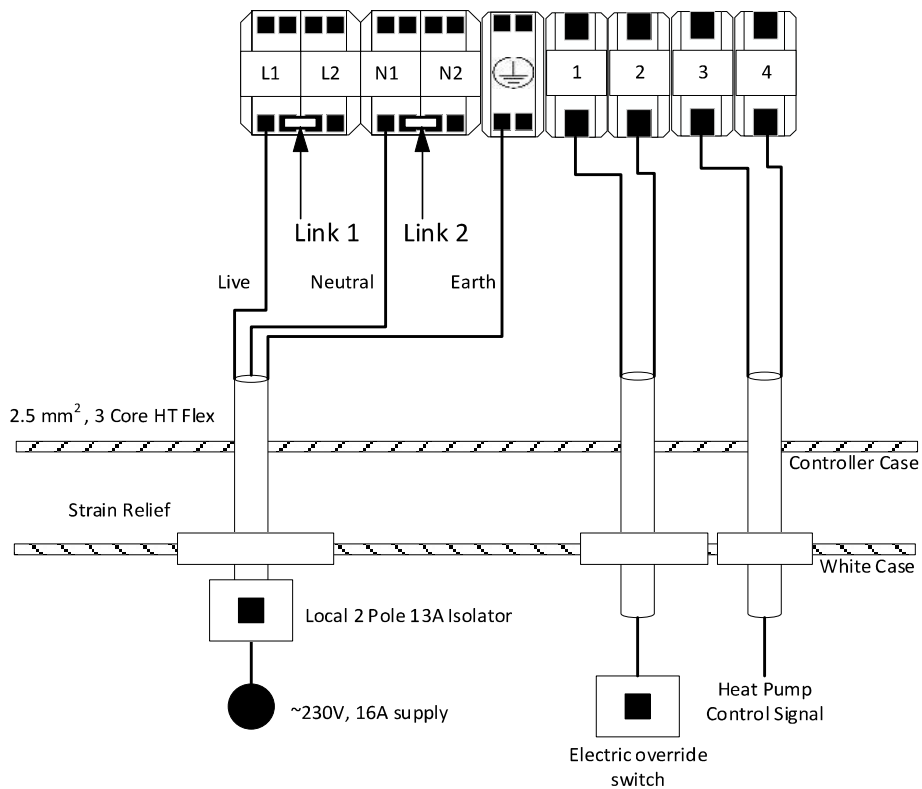

Figure 13.2: Wiring Option 2 – HW +iLTHP Daikin Low Temperature Heat Pump

4 Commissioning



Before commissioning works, first ensure that you have properly reviewed the previous sections, particularly in regard to Heat battery specifications as well as location, electrical supply and water supply requirements.

4.1 Preparation

- Ensure all packaging material has been removed.
- Ensure all components are clean and undamaged.

4.2 Process

1. Turn on the water supply and ensure that there are no leaks.
2. Fully open any hot water taps in the dwelling and allow to run for a **minimum time of 2 minutes**. This is for any air to leave the system. This may vary depending on Sunamp Ltd. Heat Battery model size.

Note: For larger models such as the HW 9 +iLTHP , the **minimum time is increased to 4 minutes**.

3. Switch ON the power supply to the Heat Battery, via the 2-pole Isolator Switch.
4. Switch ON the power supply to the Heat Pump, via its dedicated isolator.
5. On the Heat pump controller setting for hot water heating:
 - a. Please set target hot water cylinder temperature: 65 – 70°C
6. The flow rate in the heat battery charging circuit should be adjusted so that the temperature difference between flow and return is between 5 – 7°C.
7. Test the Electric override switch and check if the operation of the Low Temperature Heat Pump is disabled and the Heat Battery switches to charging via the heating element.
8. Continue to run the tap for a further **2 minutes**, then close.
9. Check the front of the Heat Battery to ensure that the “power” and “heater” LED’s are lit (see Table 15).
10. Allow the Heat Battery to charge for approximately **30 minutes** with the hot water tap closed.

Sunamp

11. After 30 minutes open the hot water tap and check for hot water.
12. Adjust the Thermostatic Mixing Valve (TMV) so that the output temperature is **45°C to 55°C**.
13. Check hot water temperature at all hot water outlets in the dwelling with the customer and advise on temperature settings.
14. Ensure that the Heat Battery charges to half charge and that there are no lights flashing (which may otherwise indicate an error, see table 13, below).
15. Leave all product information and literature with the customer / end user.
-  16. Fill in and return the Sunamp Ltd. commissioning certificate, provided with the product. **These documents MUST be compiled and returned to Sunamp after installation.**

5 Operation



Always read the safety instructions in Section 1 of the manual before operating the **UniQ HW +iLTHP** Heat Batteries.

5.1 Switch On/Off

Power is supplied to the Heat Battery via the 2-pole Isolator Switch. The Heat Battery will remain in operation whilst it is connected to the mains. The Heat Battery will switch off if you disconnect it from the mains.

5.2 LED Indicators and Status

LED Indicators are available to observe the status of the UniQ HW +iLTHP Heat Battery installed.





	Status	Meaning
	OFF	Power OFF
	ON	Power ON
	Pulsing	Heat Battery charging from 0 - 50%
	ON	Heat Battery charge level >50%
	Off	Heat Battery charge level 0 - 50%
	Pulsing	Heat Battery charging from 50 - 100%
	Solid	Heat Battery charge level 100%
	Off	Heating element INACTIVE
	Solid	Heating element ACTIVE

Table 15: LED indicators

5.3 Troubleshooting

5.3.1 During Installation

Fault	Possible Cause(s)	Possible Solution
<p>The appliance does not deliver hot water after installation</p>	<p>Issue with Low Temperature Heat Pump</p>	<p>Refer to Low Temperature Heat Pump manual, the electric override switch can be used to supply hot water in this instance. Given there are no issues with the power supply to the Heat Battery. Please note this will result in higher electricity costs if this is activated in a continuous mode.</p>
	<p>Appliance not powered or not powered correctly</p>	<p>Check wiring and power supply and rectify where necessary</p>
	<p>Non-self-resetting thermal cut-out has tripped</p>	<p>Make sure the appliance is full of water and purge if necessary:</p> <ol style="list-style-type: none"> 1. Disconnect the power supply 2. Open the electrical cover at the base of the unit 3. Reset the non-self-resetting thermal cut-out 4. Reassemble the unit, and 5. Reconnect the supply. <p>If the problem persists, please contact Sunamp Ltd.</p>
<p>LED D4 (power symbol) is rapidly flashing</p>	<p>Temperature sensor string is faulty</p>	<p>Check that the sensor cable is properly connected to the PCB and that the connector block is properly pushed in.</p> <p>If the problem persists, please contact Sunamp Ltd.</p>
<p>The flowrate from the appliance is</p>	<p>Air might still be trapped in the system</p>	<p>Check that the mains supply valve is fully opened.</p> <p>Make sure the appliance is fully de-aired and purge if necessary.</p>

lower than expected	Incoming water pressure is too low	Measure the incoming pressure from the mains supply and contact Sunamp Ltd.
----------------------------	------------------------------------	--

Table 16: Installation Troubleshooting

5.3.2 After Installation or During Use



Warning: This product does not contain any user-serviceable or user-settable components. All fault-finding and fault-remediation works therefore need to be carried out by a competent person

Fault	Possible Cause(s)	Possible Solution
No hot water	Issue with Low Temperature Heat Pump	Refer to Low Temperature Heat Pump manual, the electric override switch can be used to supply hot water in this instance. Given there are no issues with the power supply to the Heat Battery. Please note this will result in higher electricity costs if this is activated in a continuous mode.
	Power supply has been temporarily or permanently disconnected.	Check power supply, If power supply ON call your installer. If power OFF, switch on and wait for hot water. If power supply fails again call installer.
	The off-peak switch is not on (if fitted)	
Water leak	Various	Isolate the water and electricity supply to the unit and contact your installer.

Table 17: Post-installation troubleshooting

6 Maintenance



Where undertaking maintenance, repairs, or removals and where necessary, ensure that the system is first disconnected from the electrical and/or water supply.

- The product does NOT require any regular maintenance.
- In areas, where the mains water hardness can exceed 150 ppm Total Hardness and a scale-reducing device has been fitted, the service and maintenance requirements of this device (especially re-fill requirements) need to be adhered to.
- The air pressure in the expansion vessel should be checked every 2-3 years and topped up if necessary.
- If the supply cord is damaged, it must be replaced by the manufacturer, its service agent or similarly qualified persons in order to avoid a hazard, please refer to the Electrical wiring sections (3.6 - 3.8).

6.1 Removal of Lids



Warning: Disconnect power mains before accessing (live components on PCB). **Strictly no live parts.**

- The lid of the Sunamp Ltd. Heat Battery is fixed to the outer case using **2 x M5 Button Head capscrews**. These can be undone by using a **3mm hexagonal Allen key** (Figure 7).
- The terminal cover plate can be removed by unscrewing the **2 x M5 Button Head capscrews**. These can be undone by using a **3mm hexagonal Allen key**.
- The lid of the controller cover is a snap fit lid to be pried off with a flat head screwdriver to be removed.

6.2 Cleaning

- The product does not require any regular cleaning.
- Should the product exterior have become dirty it can be wiped down with a damp cloth and a mild detergent (such as soap) after having been isolated from the electricity supply. Let the appliance dry before reconnecting the electricity supply.

6.3 Warranty



All information regarding Sunamp Ltd.'s product warranty can be found at: www.sunamp.com/warranty

7 Recycling and Disposal

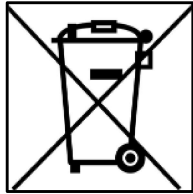

This symbol on the product and accompanying documents means the product should not be mixed with general household waste at the end of its life.

For proper treatment, recovery and recycling, please take this product to designated collection points where it will be accepted free of charge at the end of its life.

Disposing of this product correctly will help save valuable resources and prevent any potential negative effects on human health and the environment, which could otherwise arise from inappropriate waste handling.

Please contact your local authority for further details of your nearest designated collection point. Penalties may be applicable for incorrect disposal of this waste, in accordance with your national legislation.

Sunamp

Manual Part Number: D0004

Version Number: 1.1

Publication Date: 14/07/2020

Sunamp Ltd.
1 Satellite Park
Macmerry
East Lothian
Scotland, EH33 1RY
General Enquiries +44 (0)1875 610001
info@sunamp.com
www.sunamp.com

Sunamp