

Cyclone Air Direct, Indirect, Solar & High Gain Unvented Cylinder Installation & Maintenance Manual



**REGISTER THIS PRODUCT
ONLINE WITHIN 28 DAYS OF
COMMISSIONING**

IRELAND



www.joule.ie/register-a-product

UNITED KINGDOM



www.jouleuk.co.uk/register-a-product



- **This appliance can be used by children aged from 8 years and above and persons with reduced physical, sensory or mental capabilities or lack of experience and knowledge if they have been given supervision or instruction concerning use of the appliance in a safe way and understand the hazards involved. Children shall not play with the appliance. Cleaning and user maintenance shall not be made by children without supervision**
- **Water may drip from the discharge pipe of the pressure-relief device and that this pipe must be left open to the atmosphere**
- **The pressure-relief device is to be operated regularly to remove lime deposits and to verify that it is not blocked**
- **For an appliance intended to be permanently connected to the water mains and not connected by a hose-set, this is stated**
- **A discharge pipe connected to the pressure-relief device is to be installed in a continuously downward direction and in a frost-free environment**
- **The fixed wiring must be protected due to excessive heat produced by the appliance**
- **Max. inlet water pressure 7bar (0,7MPa)**
- **Min. inlet water pressure 3bar (0,3MPa)**

Warranty Card

Please register your product online

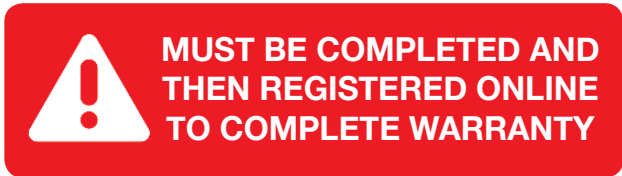

Homeowner Name

Address

Contact Tel.

Contact Email

Installer Name

Address

Contact Tel.

Contact Email

Product	Product Installed	Serial Number	Installation Date
Cylinder	<input type="radio"/>		Located on cylinder badge
Solar Thermal	<input type="radio"/>		Take from solar controller
Solar PV	<input type="radio"/>		Ser. No. from String / Micro Inverter
Air Source Heat Pump	<input type="radio"/>		Located on external heat pump badge
Integrated Heat Pump and Cylinder	<input type="radio"/>		Located on cylinder badge
Underfloor Heating	<input type="radio"/>		Project ref. on supplied schematic
Direct Gas Fire Cylinder	<input type="radio"/>		Located on cylinder badge
Was a Pre-Plumbed cylinder installed too?	<input type="radio"/>	If installed, please fill out the Heat Pump Commissioning Sheet too	

Joule™ Cyclone Air Installer

I accept the terms and conditions in the installation manual

JOULE™ Product Warranty Terms & Conditions

JOULE™ Cylinders

The **JOULE™ Cyclone Air** stainless steel vessel carries a fully transferable 25-year guarantee against faulty materials or manufacture provided that:

- It has been installed in the United Kingdom or the Republic of Ireland as per the instructions provided in the installation manual provided with the cylinder and in accordance with all of the relevant standards, regulations and codes of practice in force at the time.
- It has not been modified in any way, other than by JOULE™
- It has not been misused, tampered with or subjected to neglect.
- The system is fed from the public mains water supply.
- It has only been used for the storage of potable water.
- It has not been subjected to frost damage.
- The unit has been serviced annually.
- The Service Log Book has been completed after each annual service.
- The warranty card is filled in and a copy is sent by email to **warranty@joule.ie**

Exclusions

The guarantee does not cover cylinders affected by the following;

- The effects of scale build up on the cylinder.
- Any labour charges associated with replacing the unit or its parts.
- Any consequential losses caused by the failure or malfunction of the unit.

Please note that invoices for servicing may be requested to prove that the unit has been serviced annually.

Unvented Kit & Other Components

The cold water controls supplied with JOULE models carry a 2-years guarantee. All other components that are fitted to, or supplied, with the unit carry a 2-years guarantee.

Warning To The User

- Do not remove or adjust any part of this unvented water heater.
- If the unvented water heater develops fault, such as a flow of water from the discharge pipe switch the heater off.
- In all cases contact a competent installer.
- The Benchmark Log Book at the end of the manual must be filled in at annual service.

Warning To The Installer

- Read the installation instructions before commencing.
- Unvented water heaters are a controlled service as defined in the latest edition of the Building Regulations and should only be fitted by a competent installer.
- The installation is subject to building regulation approval.
- You must notify the local authority of intention to install.
- After installation the instructions manual must be completed and left with the householder.
- Use only manufacturer's recommended replacement parts.

Installed by

Installer Name

Address

Contact Tel.

Completion Date

Table Of Contents

6	Introduction	
10	General Requirements	
14	Unvented Kit Components	
15	Unvented Kit Checklist	
16	ErP Product Fiche	
17	Technical Data	
18	Indirect Technical Specification	
20	Direct Technical Specification	
22	Solar Technical Specification	
24	High Gain Specification	
26	High Gain Solar Specification	
28	Plumbing G3 Unvented Kit	
29	Testing	
30	Smart Control Immersion Setup	NEW
	Un-Plumbed Cylinder Schematic	
32	• Mechanical Diagram S-Plan	
33	• Electrical Diagram S-Plan	
	Un-Plumbed Cylinder Schematic	
34	• Mechanical Diagram Y-Plan	
35	• Electrical Diagram Y-Plan	
36	Electronic Controls	
37	Discharge Arrangement	
40	Commissioning	
42	User Instructions	
44	Maintenance	
46	Taking The Cylinder Out Of Use	
48	Troubleshooting	
50	Benchmark Checklist	
52	Service Record	
53	Notes	

Introduction

The instructions are an integral part of the appliance and must be given to the end user on completion of the installation in order to comply with the current regulation.

It is important to carefully read the manual to understand all the information to enable safe installation, use and servicing. These instructions consist of details for installation, servicing, fault finding and replacement of parts for the cylinder purchased.

JOULE™ will not accept any liability in the event of damage for not complying with the guidance in this instruction manual.

The instructions for this installation manual apply to the range of **JOULE™ Cyclone Air Unvented Cylinders**.

Safety is paramount when installing unvented hot water systems and the following instructions must be adhered to:

- Only certified competent installers can install, commission and service the equipment supplied.
- The cylinder must be used for potable hot water only. Any other applications will be considered incorrect use and JOULE™ will not be held liable for any losses resulting from such use.
- All installation and maintenance instructions must be observed to ensure the correct operation of the equipment.
- The electric immersion must not be switched on unless the cylinder is completely full of water.
- Domestic hot water may be stored at temperatures exceeding 60°C. Preventative measures should be put in place to negate the possibility of scalding.
- A maintenance schedule should be put in place with a competent person to service the equipment annually to comply with the warranty conditions.
- When servicing the system the mains supply to the cylinder should be isolated.
- Only genuine spare parts should be used. A full list of items with relevant codes can be found on page 14.

The installation must be carried out by a person competent to install unvented hot water systems. The installation must be carried out in accordance with the following recommendations:

All current Building Regulations issued by the Department of the Environment, i.e. Building Regulation G3 (England and Wales), Technical Standard P3 (Scotland) or Building Regulation P5 (Northern

Ireland) and the Water Fitting Regulations (England and Wales) or Water Byelaws (Scotland). The

installation should also be in accordance with the following British Standard Codes of Practice:

BS 5449:1990 Forced circulation hot water systems

BS 5546:2000 Installation of hot water supplies for domestic purposes

BS 5918:1989 Solar heating systems for domestic hot water

BS 6700:2006 Design, installation, testing and maintenance of services supplying water.

Failure to install this appliance correctly could lead to prosecution and will invalidate the guarantee. It is in your own interest and that of safety to ensure that the law is complied with.

Handling

Care must be taken when transporting, storing and installing the equipment:

- At least two people should lift the cylinder to prevent injuries.
- The cylinder must be stored in a dry area and must never be set down hard during handling.
- Packaging should only be removed at the installation location.
- The cylinder must be installed on a level or with the required load bearing capability. Installation, servicing, maintenance and repair must be carried out by a competent person.
- All electrical wiring must be carried out by a qualified electrician and be installed in accordance with current I.E.E Wiring Regulations.
- A lack of safety devices can lead to potentially fatal injuries, all necessary safety devices must be installed correctly in the system. The use of an electric immersion may lead to the build up of electrical potential in the water. This can in turn cause corrosion of the immersion. To prevent this, ensure the immersion heater, and the hot and cold pipework are correctly bonded and connected to the earth line.
- If plastic pipes are used they must be approved temperature resistant to 95°C at a pressure of 10bar.

A thermostatic mixer should be installed in the system to prevent the risk of scalding. If there are leaks found in the system, shut off the cold water stop valve from the main supply and contact a competent person immediately.

What Is Benchmark?

Benchmark places responsibilities on both manufacturers and installers. The purpose is to ensure that customers are provided with the correct equipment for their needs, that it is installed, commissioned and serviced in accordance with the manufacturer's instructions by competent persons and that it meets the requirements of the appropriate Building Regulations.

The Benchmark Checklist can be used to demonstrate compliance with Building Regulations and should be provided to the customer for future reference. Installers are required to carry out installation, commissioning and servicing work in accordance with the Benchmark Code of Practice which is available from the Heating and Hot Water Industry Council who manage and promote the scheme. Visit www.centralheating.co.uk

HWA Charter Member

JOULE™ are proud to be a charter member of the the Hot Water Association (HWA), who has been formed through the union of the two UK industry trade bodies, WMA (Water Heater Manufacturers Association) and MODUS (Manufacturers Of Domestic Unvented Systems).

The objectives of the HWA are “To be recognised as the leading body in domestic hot water storage and, through cooperation and partnerships, to support, drive and promote the sustained growth and improvement of standards within the entire domestic hot water industry”.

The HWA operate a Charter that all members of the association observe.

The HWA Charter Statement requires that all members adhere to the following:

- To supply fit for purpose products clearly and honestly described
- To supply products that meet or exceed appropriate standards and building and water regulations
- To provide pre and post technical support
- To provide clear and concise warranty details to customers

Introduction

Water Supply

The performance of any unvented system is only as good as the mains water supply available. To this extent the maximum possible water demand should be assessed, with the knowledge that the mains supplies both hot and cold services simultaneously. The water heater itself operates at a pressure of 3bar, controlled by the inlet control set, and is capable of delivering over 50 litres per minute. The high quality inlet control set has been designed to make the most of the low rates available.

The water supply should be checked to ensure it can meet these requirements. If necessary, consult the local water authority regarding the likely pressure and flow rate availability.

Consideration should be given to upgrading existing 1/2" (15mm) cold mains pipework to a larger size if the recommended minimum pressure / flow rate is not being achieved. JOULE™ recommend that primary pipework used has a minimum diameter of 22mm to ensure low pressure loss.



A high static (no flow) mains pressure is no guarantee of good flow availability. In a domestic installation 1.5bar and 25ltr/min should be regarded as the minimum. The maximum mains pressure that the inlet control set can cope with is 10bar.

Change Of Water Supply

The changing or alternating from one water supply to another can have a detrimental effect on the operation and/or life expectation of the water heater storage cylinder, pressure temperature relief valve and heating unit.

Where there is a changeover from one water supply to another, e.g. a rainwater tank supply, bore water supply, desalinated water supply, public reticulated water supply or water brought in from another supply, then water chemistry information should be sought from the supplier or it should be tested to ensure the water supply meets the requirements given in these guidelines for the JOULE™ warranty to apply.

Water Chemistry

This water heater must be installed in accordance with this advice to be covered by the JOULE™ warranty. This water heater is manufactured to suit the water conditions of most public reticulated water supplies. However, there are some known water chemistries which can have detrimental effects on the water heater and its operation and/or life expectancy. If you are unsure of your water chemistry, you may be able to obtain information from your local water supply authority. We recommend not to use water softener, however if it is used the water is required to be kept at potable standards. This water heater should only be connected to a water supply which complies with these guidelines for the JOULE™ warranty to apply.

Water Chemistry Levels Affecting Warranty

The JOULE™ warranty of this water heater will not cover resultant faults on components including the storage cylinder where water stored in the storage cylinder exceeds at any time any of the following levels:

Components	Maximum Permitted Levels
Total Dissolved Solids	600 mg/litre
Total Hardness	200 mg/litre
Chloride	300 mg/litre
Magnesium	10 mg/litre
Calcium	20 mg/litre
Sodium	150 mg/litre
Iron	1 mg/litre
Maximum pH	9.5
Minimum pH	6.5

Total Dissolved Solids (TDS)

Some water analysis reports may state the conductivity of the water rather than the level of total dissolved solids. Conductivity, measured in microsiemens per centimetre ($\mu\text{S}/\text{cm}$), is directly proportional to the TDS content of the water. TDS, in mg/L, is approximately 70% of the conductivity in $\mu\text{S}/\text{cm}$.

The JOULE™ warranty will not cover resultant faults to the storage cylinder if this water heater is connected at anytime to a water supply where the TDS content of the water exceeds 600 mg/L. In locations where TDS approaches 600 mg/L, e.g. due to sediment, we strongly recommend fitting an appropriate filter to ensure water entering or in the water heater does not exceed this level at any time i.e. due to sediment build up.

Features Of The Unvented Cylinder

- Made from Duplex Stainless Steel for excellent corrosion resistance.
- Strong rust-proofed steel case.
- Insulation is by means of an approved CFC/HCFC free polyurethane foam with an ozone depletion factor of zero.
- Available in a variety of sizes to suit - 100L, 125L, 150L, 170L, 180L, 200L, 210L, 250L and 300L litres.
- All safety and control devices are pre-set.
- High quality controls selected that combine high flow rate performance with minimum pressure drop which gives fantastic performance in all areas, with great improvements in areas with poor water pressure.

General Requirements

Siting The Unit

This unit can supply outlets above it or at some distance from it but any outlets above the unit will reduce the available outlet pressure by 0.1 bar for every 1m of height difference. The maximum length of the “dead leg” should be as stated in the Water Supply (Water Fittings) Regulations 1999 G18.7, in particular to the area of most frequent use.

Particular attention is needed if sitting in a garage or outbuilding as the unit should be protected from frost. All exposed pipework must be insulated. The unit must be installed **upright** on a flat base capable of supporting its weight when full (please see the technical specification section for weights).

Sufficient access to allow maintenance of the valves should be considered. In addition the immersion heaters are 400mm in length and this distance should be considered to allow withdrawal for servicing if required. The discharge pipework from the safety valves should fall continuously and terminate safely.

Negative pressure may form in cylinders installed very high in a building. To counteract this, an anti-vacuum valve can be installed to prevent damage to the cylinder. The anti-vacuum valve ensures that pressure compensation as a result of air flowing into the cylinder.

Connecting To The Cylinder

All of the pipework connections on the cylinder are female threaded. Upon filling / commissioning, ensure all connections are completely watertight.



No control or isolation valve should be fitted between the expansion relief valve and the storage cylinder. The relief valve connections should not be used for any other purpose.

Cold Mains Pipework

Run the cold main through the building to the place where it is to be installed. Take care not to run the cold pipe near hot water or heating pipe work so that the heat pick-up is minimized. Identify the cold water supply pipe and fit an isolating valve (not supplied). A 22mm BS1010 stopcock can typically be used but a 22mm quarter turn full bore valve would be better as it does not restrict the flow as much. Do not use “screwdriver slot” or similar valves.

Make the connection to the cold feed of the cylinder and incorporate a drain valve. Position the inlet control just **above** the Temperature & Pressure Relief Valve (TPRV) mounted on the side of the cylinder. This ensures that the cylinder does not have to be drained down in order to service the inlet control set. Ensure that the arrow points in the direction of the water flow.

Balanced Cold Connection

If there are to be showers, bidets or monobloc taps in the installation then a balanced cold supply is necessary. There is a 22mm balanced connection on the inlet control set.

Fitting The Inlet Control Group

Excess pressure can lead to the cylinder bursting. The inlet control set supplied has an expansion relief valve with a 15mm connection to allow it to be connected to the tundish. Make sure that there is sufficient space for future maintenance and also for connection of the discharge pipe for the expansion relief valve. It is essential that this connection is not covered or closed.

Hot Water Pipework

Run the first part of the hot water distribution pipework in 22mm. This can be reduced to 15mm and 10mm as appropriate for the type of tap etc. Your aim should be to reduce the volume of the hot draw-off pipework to a practical minimum so that the time taken for the hot water is as quick as possible.

Do not use monobloc mixer tap or showers if the balanced cold connection is not provided. Outlets of this type can back pressurise the unit and result in discharge.

General Requirements

Primary Coil Connections

Connect the primary connections (Indirect only). The primary circuit must be positively pumped. Either primary connection may be used as the primary flow. Reheat times are identical either way. The primary circuit can be open vented or sealed, with up to a maximum pressure of 3.5 bar. If you seal the primary circuit an additional safety valve is required.

The boiler may be Gas, Electric or Oil but must be under effective thermostatic control. Uncontrolled heat sources such as some AGA's, back boilers, solid fuel stoves, etc. are **not suitable**. Please contact our Technical department for guidance. Connect the two port zone valve (indirect only) into the primary flow pipework. The direction of flow arrow should be towards the primary flow connection.

Installing The Two Port Motorised Valve

The function of the Two Port Motorised Valve prevents the cylinder from overheating. It can be installed on either horizontal or vertical pipework.

If it is mounted onto horizontal pipework the valve head must face upwards. The direction of flow is marked on the body of the valve with arrows.

Thermostatic Mixer

When installing a solar system with an unvented JOULE™ Cyclone twin coil cylinder, a thermostatic mixing valve should be installed. Its function is to act as an anti scald protection. The thermostatic mixer is to be set to a temperature of between 30°C and 60°C and is supplied by the installer.

Secondary Circulation

On larger installations long pipe runs to draw-off points can cause significant volumes of water to be drawn off before an acceptable temperature can be reached. Secondary pumped circulation using a stainless steel or a bronze pump, and combined with effective time and temperature controls can overcome this problem. Where secondary return circulation is required the pipework should be run in 15mm pipe. A suitable WRAS approved stainless steel or bronze circulation pump must be used. A check valve must also be installed to prevent back flow.

On large secondary circulation systems it may be necessary to incorporate an extra expansion vessel into the circuit to accommodate the increased system water volume. Secondary circulation should be avoided on Direct electrically heated units being used on off-peak electricity tariffs. It should be noted that the use of a secondary circulation circuit can increase running costs as there will be circulation pipe losses. High levels of insulation on secondary pipework are required to keep energy losses to a minimum.

Dead Legs

The length of hot water draw off to taps and other outlets should be kept to a minimum to reduce the amount of cold water drawn off before the hot water arrives. Where there is more than one size of pipe on a dead leg, the equivalent length and size should be estimated. Where the dead leg length exceeds the recommended maximum, secondary circulation should be installed. It should be controlled by a time switch and incorporate a motorized valve that can prevent gravity circulation in the circuit.

Pipe Size (mm)	Maximum Length (m)
10, 12	20
15, 22	12
28	8
35 and above	3

System Noise

Noise in pipework may occur as a result of expansion of pipework over joists or where the pipe has been left touching other pipes or a part of the building structure. Care must be taken to ensure that the pipework is correctly bracketed, is not in tension or compression, and does not carry the weight of components such as a circulation pump.

Setting The Hot Water Temperature

The hot water temperature is set on the dual thermostat by the competent person during the installation. The dual thermostat should be set to 60°C. If you are heating water in the cylinder for the first time, or the time controls for the DHW zone have been off for a prolonged period of time, the cylinder may take additional time to heat up.



Inappropriate adjustments can lead to the damages in the system. In any changes are made to the cylinder, the controls, the water and power supply lines or the expansion relief components there is a risk of steam escaping or rupture to the

Unvented Kit Components



TZ9-010-0000.5



TZM-I-00022MM



TZC-D-000000Z



TZU-000015X22



TZG-3.0-A0.75I



TI-I-L-14-3-1

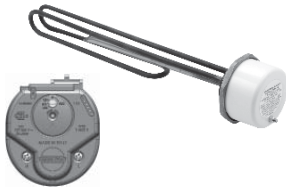

TI-S-L-14-3-1

Unvented Kit Checklist

Capacity (ltr)	100	125	150	170	180	200	210	250	300
Inlet Group									
T&P Valve									
Tundish									
Dual Stat									
Prim. Coil 2-P Z.Valve									

Direct	Indirect
Inlet Control Group	Inlet Control Group
Tundish	Tundish
T&P Valve (fitted)	T&P Valve (fitted)
2 x 3kW Immersion (fitted)	3kW Immersion (fitted)
	Dual Cylinder Stat
	2-port Zone Valve

ErP Product Fiche Information

According to EN 12897:2016

Nominal Capacity (ltr)	100	125	150	170	180	200	210	250	300
Direct SMART IMMERSION									
Storage volume V (ltr)	105	112	139	180	179	198	214	236	277
Mixed water at 40°C (ltr)	158	168	209	270	269	297	321	354	416
The declared load profile	L	L	L	L	L	L	L	L	XL
ErP Rating	C	C	C	C	C	C	C	C	C
Energy Efficiency (%)	39	39	38	38	38	38	38	37	37
Ann. el. consumption (kWh)	2641	2646	2707	2711	2715	2715	2723	2752	4495
Sound Power Level (dB)	16	16	16	16	16	16	16	16	16
Thermostat Temp. Set. (°C)	60	60	60	60	60	60	60	60	60
Daily En. Usage Qelec (kWh/24h)	12.140	12.164	12.528	12.552	12.577	12.577	12.625	12.795	20.889

Nominal Capacity (ltr)	100	125	150	170	180	200	210	250	300
Indirect									
Storage Volume V (ltr)	115	109	136	177	176	195	211	232	274
Standing Loss (kW)	40	48	51	54	54	77	78	85	92
ErP Rating	B	B	B	B	B	C	C	C	C

Nominal Capacity (ltr)	100	125	150	170	180	200	210	250	300
Solar									
Storage Volume V (ltr)	-	-	-	174	173	191	208	228	276
Standing Loss (kW)	-	-	-	54	54	77	78	85	92
ErP Rating	-	-	-	B	B	C	C	C	C

Nominal Capacity (ltr)	100	125	150	170	180	200	210	250	300
High Gain									
Storage Volume V (ltr)	-	-	-	164	163	183	200	219	259
Standing Loss (kW)	-	-	-	54	54	77	78	85	92
ErP Rating	-	-	-	B	B	C	C	C	C

Nominal Capacity (ltr)	100	125	150	170	180	200	210	250	300
High Gain Solar									
Storage Volume V (ltr)	-	-	-	-	-	180	197	220	257
Standing Loss (kW)	-	-	-	-	-	77	78	85	92
ErP Rating	-	-	-	-	-	C	C	C	C

ErP Product Fiche Information

According to EN 12897:2016

Nominal Capacity (ltr)	100	125	150	170	180	200	210	250	300
Direct STANDARD IMMERSION									
Storage volume V (ltr)	105	112	139	180	179	198	214	236	277
Mixed water at 40°C (ltr)	158	168	209	270	269	297	321	354	416
The declared load profile	L	L	L	L	L	L	L	L	XL
ErP Rating	C	C	C	C	C	C	C	C	C
Energy Efficiency (%)	37	37	37	37	37	35	35	35	37
Ann. el. consumption (kWh)	2740	2773	2785	2797	2801	2892	2900	2908	4573
Sound Power Level (dB)	16	16	16	16	16	16	16	16	16
Thermostat Temp. Set. (°C)	60	60	60	60	60	60	60	60	60
Daily En. Usage Qelec (kWh/24h)	12.722	12.916	12.989	13.062	13.086	13.619	13.668	13.716	21.350

Technical Data

Indirect models in conformance with EN 12897:2016

Maximum mains water supply pressure	2.5MPa (25 bar)
Operating pressure/PRV	0.4MPa (4 bar)
Expansion relief valve setting	0.8MPa (8 bar)
Maximum design pressure	0.6MPa (6 bar)
T&P relief valve setting	1.0MPa/90 °C (10 bar)
Primary coil operating pressure (max)	0.6MPa (6 bar)
Immersion heater rating (a.c. supply only) single phase	3kW 50/60Hz ~
Storage weights (empty and full)	See Specification Tables
Indirect coil ratings	See Specification Tables
Pressure drop across the indirect coils	See Specification Tables
Coil surface area	See Specification Tables

Indirect Technical Specification

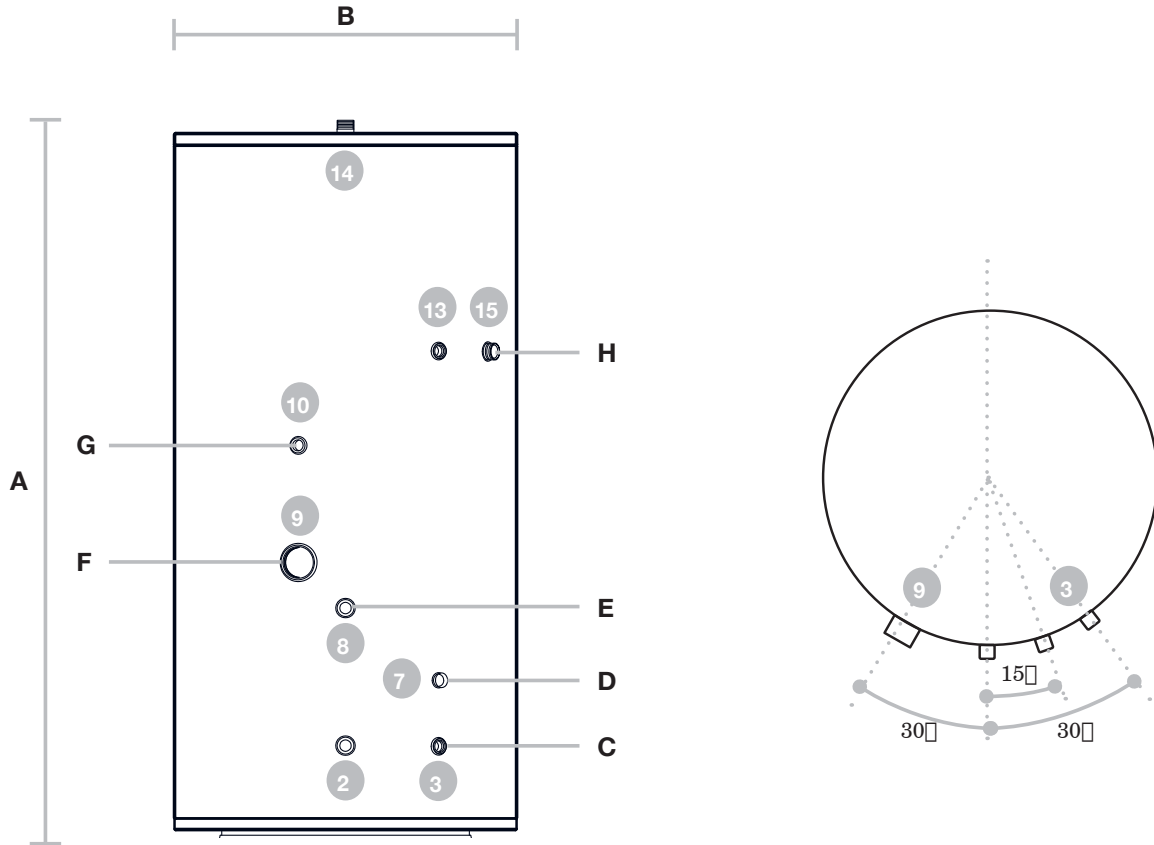

Legend

- 2 Boiler Return
- 3 Drain
- 7 Aquastat Pocket
- 8 Boiler Flow
- 9 Incoloy Immersion (fact. fitted)
- 10 Secondary Return
- 13 T&P Relief Valve
- 14 Hot Water Draw Off
- 15 Cold Water Inlet

Connection Sizes & Safety		100	125	150	170	180	200	210	250	300
Hot & Cold Conn. Ø(mm)		22	22	22	22	22	22	22	22	22
Coil Connection Ø (mm)		22	22	22	22	22	22	22	22	22
Secondary Return Ø BSP (")		0.5	0.5	0.5	0.5	0.5	0.5	0.5	0.5	0.5
T&P Connection Ø BSP (")		0.5	0.5	0.5	0.5	0.5	0.5	0.5	0.5	0.5
3 bar	T&P Press. Sett. (bar)	10	10	10	10	10	10	10	10	10
	Exp. Relief Set. (bar)	8	8	8	8	8	8	8	8	8

Dimensions	100	125	150	170	180	200	210	250	300
Cylinder Height A (mm)	950	1030	1190	1310	1370	1490	1510	1815	2060
Cylinder Diameter B (mm)	540	540	540	540	540	540	540	540	540
Connection Height C (mm)	195	195	195	195	195	195	195	195	195
Connection Height D (mm)	320	320	340	340	340	335	335	360	360
Connection Height E (mm)	445	445	485	485	485	515	335	585	585
Connection Height F (mm)	500	500	550	550	550	580	580	650	650
Connection Height G (mm)	580	580	655	735	795	830	930	1080	1255
Connection Height H (mm)	640	640	780	880	940	1020	1120	1315	1530

Performance	100	125	150	170	180	200	210	250	300
Heat Up Time 10°C to 60°C (min)	25	20	26	33	32	37	40	43	50
1st Re-Heat time (70% dr. off) 15L/m	18	14	18	23	22	26	28	30	35
Weight Empty (kg)	47	48	50	54	56	58	61	64	74
Weight Full (kg)	162	157	186	231	232	253	272	296	348
Prim. Coil Surf. Area (m ²)	0.58	0.58	0.58	0.58	0.58	0.67	0.67	0.77	0.77
Heat Exchanger Rated Volume (L)	2.7	2.7	2.7	2.7	2.7	3.2	3.2	3.6	3.6
Prim. Coil Rat. @15L/m (kW, 80±2°C)	11.6	14.3	13.9	14.2	14.5	14.2	13.9	14.9	13.9
Pr. Coil Press. Drop @ 60L/hr (mbar)	45	45	45	45	45	65	65	76	76
Cont. Output (L/hr)	200	247	238	244	250	244	239	256	240
Cold Water Capacity	115	109	139	177	176	195	211	232	274

Direct Technical Specification

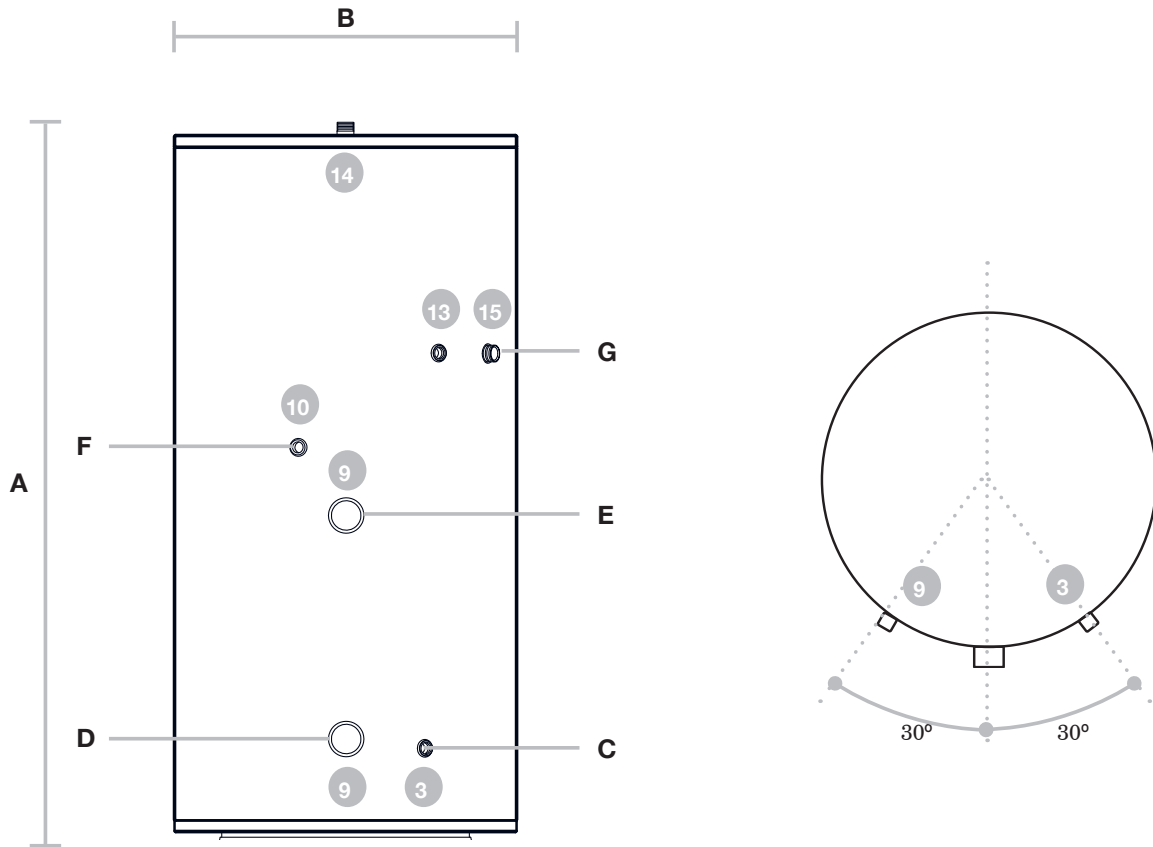

Legend

- 3 Drain
- 7 Aquastat Pocket
- 8 Boiler Flow
- 9 Incoloy Immersion (fact. fitted)
- 10 Secondary Return
- 13 T&P Relief Valve
- 14 Hot Water Draw Off
- 15 Cold Water Inlet

Connection Sizes & Safety		100	125	150	170	180	200	210	250	300
Hot & Cold Conn. Ø (mm)		22	22	22	22	22	22	22	22	22
Coil Connection Ø (mm)		22	22	22	22	22	22	22	22	22
Secondary Return Ø BSP (")		0.5	0.5	0.5	0.5	0.5	0.5	0.5	0.5	0.5
T&P Connection Ø BSP (")		0.5	0.5	0.5	0.5	0.5	0.5	0.5	0.5	0.5
3 bar	T&P Press. Sett. (bar)	10	10	10	10	10	10	10	10	10
	Exp. Relief Set. (bar)	8	8	8	8	8	8	8	8	8

Dimensions	100	125	150	170	180	200	210	250	300
Cylinder Height A (mm)	950	1030	1190	1310	1370	1490	1510	1815	2060
Cylinder Diameter B (mm)	540	540	540	540	540	540	540	540	540
Connection Height C (mm)	195	195	195	195	195	195	195	195	195
Connection Height D (mm)	210	210	210	210	210	210	210	210	210
Connection Height E (mm)	360	400	560	550	610	700	800	860	870
Connection Height F (mm)	470	565	655	735	795	835	935	1080	1255
Connection Height G (mm)	550	640	780	880	940	1020	1120	1315	1530

Performance	100	125	150	170	180	200	210	250	300
Heat Up Time 10°C to 60°C (min)	52	63	78	101	101	111	120	133	139
1□ Re-heat time (70% dr. off) 60L/m	37	44	55	71	71	78	84	93	97
Weight Empty (kg)	39	42	44	48	50	52	55	58	67
Weight Full (kg)	144	154	183	228	229	250	269	294	344
Cold Water Capacity	105	112	139	180	179	198	214	236	277
Cont. Output (L/hr)	103	103	103	103	103	103	103	103	103
Quantity Of Fact. Fitted Immersions	2								
Rating Of Factory Fitted Imm. (kW/V)	3/240								
Factory Fitted Immersion Type	1x Incoloy / 1x SMART								
Number Of Immersion Bosses	2								

Solar Technical Specification

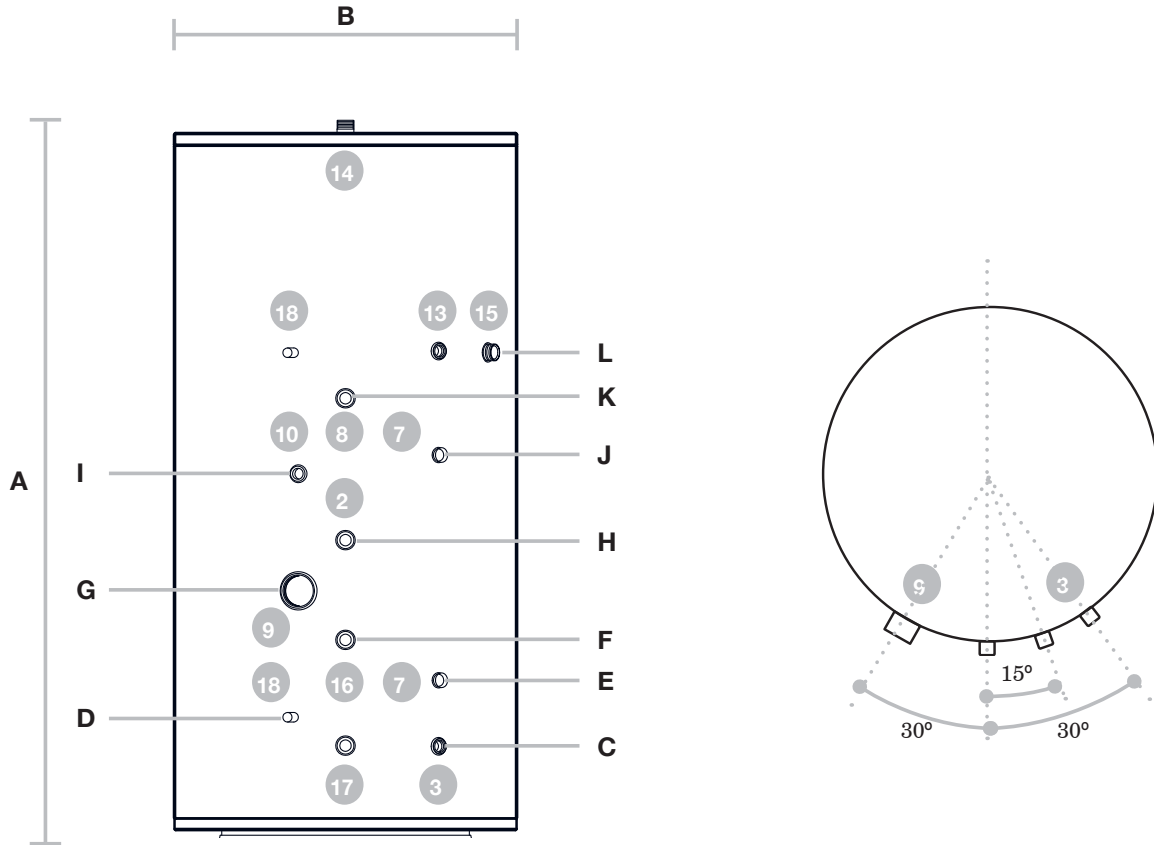

Legend

- 2 Boiler Return
- 3 Drain
- 7 Aquastat Pocket
- 8 Boiler Flow
- 9 Incoloy Immersion (fact. fitted)
- 10 Secondary Return
- 13 T&P Relief Valve
- 14 Hot Water Draw Off
- 15 Cold Water Inlet
- 16 Solar/Boiler Flow
- 17 Solar/Boiler Return
- 18 Solar Stat Pocket

Connection Sizes & Safety		170	180	200	210	250	300
Hot & Cold Conn. Ø (mm)		22	22	22	22	22	22
Primary Coil Connection Ø (mm)		22	22	22	22	22	22
Solar Coil Connection Ø (mm)		22	22	22	22	22	22
Secondary Return Ø BSP (")		0.5	0.5	0.5	0.5	0.5	0.5
T&P Connection Ø BSP (")		0.5	0.5	0.5	0.5	0.5	0.5
3 bar	T&P Press. Sett. (bar)	10	10	10	10	10	10
	Exp. Relief Set. (bar)	8	8	8	8	8	8
Dimesions		170	180	200	210	250	300
Cylinder Height A (mm)		1310	1360	1490	1510	1815	2060
Cylinder Diameter B (mm)		540	540	540	540	540	540
Connection Height C (mm)		195	195	195	195	195	195
Connection Height D (mm)		245	245	245	245	245	245
Connection Height E (mm)		340	340	335	335	360	360
Connection Height F (mm)		485	485	515	515	585	585
Connection Height G (mm)		550	550	580	580	650	650
Connection Height H (mm)		615	615	645	645	721	715
Connection Height I (mm)		735	735	790	790	1085	860
Connection Height J (mm)		740	740	835	835	860	1005
Connection Height K (mm)		842	842	935	935	1005	1255
Connection Height L (mm)		880	940	1020	1120	1315	1530
Performance		170	180	200	210	250	300
Heat Up Time (10°C to 60°C)		31	32	35	38	41	51
1st Re-Heat time (70% dr. off) 15L/m		22	22	25	27	29	36
Weight Empty (kg)		61	64	65	68	71	76
Weight Full (kg)		238	237	256	275	299	352
Prim. Coil Surf. Area (m ²)		0.58	0.58	0.58	0.58	0.58	0.58
Heat Exchanger Rated Volume (L)		2.7	2.7	2.7	2.7	2.7	2.7
Prim. Coil Rat. @15L/m (kW, 80±2°C)		12.1	12.4	12.3	12.2	12.6	15.5
Hot Water Capacity (L)		70.74	71	95	105	130	179
Prim. Coil Pr. Drop @ 15L/m (mbar)		45	45	65	65	76	76
Dedicated Solar Volume (L)		103.3	102	96	102	98	97
Solar Coil Surface Area (m ²)		0.58	0.58	0.67	0.67	0.77	0.77
Solar Coil Rating @ 15L/min (kW)		15.9	15.8	15.9	15.9	16.3	15.3
Hot Water Capacity (L)		144.6	145	159	173	191	231.43
Cont. Output (L/hr)		482	486	485	484	497	529
Cold Water Capacity		174	173	191	207	228	276

High Gain Technical Specification

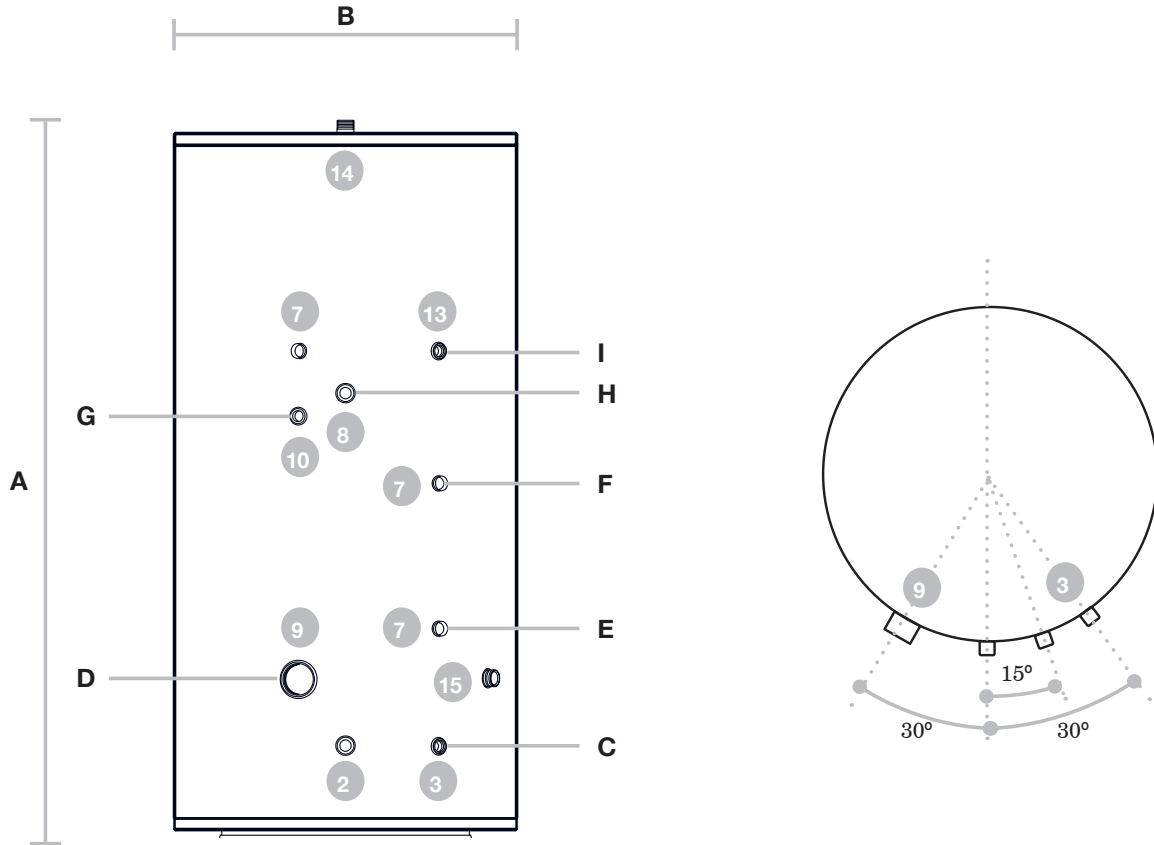

Legend

- 2 High Gain Return
- 3 Drain
- 7 Aquastat Pocket
- 8 High Gain Flow
- 9 Incoloy Immersion (fact. fitted)
- 10 Secondary Return
- 13 T&P Relief Valve
- 14 Hot Water Draw Off
- 15 Cold Water Inlet

Connection Sizes & Safety		170	180	200	210	250	300
Hot & Cold Conn. Ø (mm)		22	22	22	22	22	22
Coil Connection Ø (mm)		28	28	28	28	28	28
Secondary Return Ø BSP F (“)		0.5	0.5	0.5	0.5	0.5	0.5
T&P Connection Ø BSP F (“)		0.5	0.5	0.5	0.5	0.5	0.5
3 bar	T&P Press. Set. (bar)	8	8	8	8	8	8
	Exp. Relief Set. (bar)	10	10	10	10	10	10

Dimensions		170	180	200	210	250	300
Cylinder Height A (mm)		1310	1360	1490	1510	1815	2060
Cylinder Diameter B (mm)		540	540	540	540	540	540
Connection Height C (mm)		195	195	195	195	195	195
Connection Height D (mm)		345	345	345	345	345	345
Connection Height E (mm)		445	445	465	465	465	480
Connection Height F (mm)		725	725	760	760	760	880
Connection Height G (mm)		820	820	1085	1085	1085	1255
Connection Height H (mm)		865	865	945	945	945	1055
Connection Height I (mm)		890	950	1020	1120	1315	1530

Performance		170	180	200	210	250	300
Heat Up Time (10°C to 60°C)		16		19		21	23
1st Re-Heat time (70% dr. off) 15L/m		25		29		31	34
Weight Empty (kg)		62		66		77	86
Weight Full (kg)		232		266		327	386
Prim. Coil Surf. Area (m ²)		2.5		2.5		2.8	3.0
Prim. Coil Rat. @15L/m (kW)	ΔT 50°C	37		37		42	45
Prim. Coil Rat. @15L/m (kW)	ΔT 35°C	12		12		14	15
Pr. Coil Press. Drop @ 60L/hr (mbar)		74		74		86	86
Cont. Output @60°C (L/hr)	ΔT 50°C	636		636		722	774
Cont. Output @60°C (L/hr)	ΔT 35°C	295		295		344	369

High Gain Solar Technical Specification

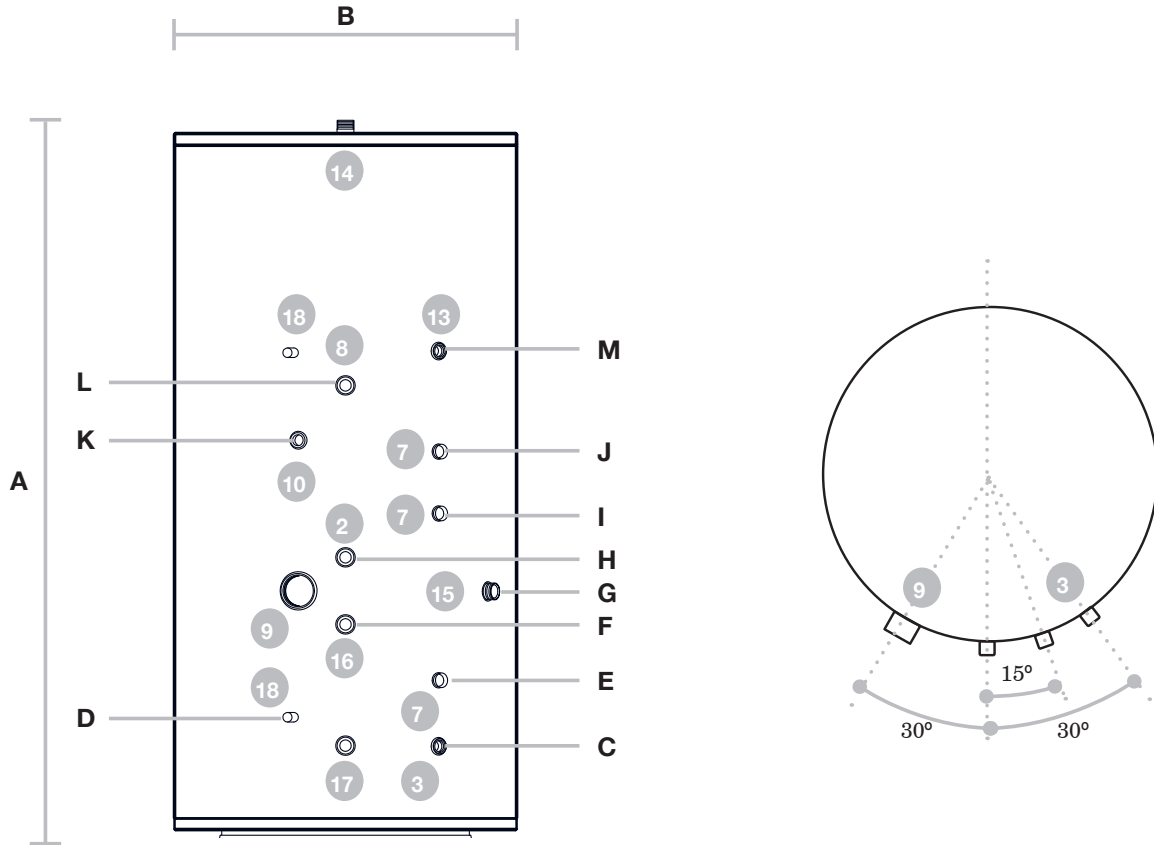

Legend

- 2 High Gain Return
- 3 Drain
- 7 Aquastat Pocket
- 8 High Gain Flow
- 9 Incoloy Immersion (fact. fitted)
- 10 Secondary Return
- 13 T&P Relief Valve
- 14 Hot Water Draw Off
- 15 Cold Water Inlet
- 16 Solar/Boiler Flow
- 17 Solar/Boiler Return
- 18 Solar Stat Pocket

Connection Sizes & Safety		200	210	250	300
Hot & Cold Conn. □ (mm)		22	22	22	22
Primary Coil Connection □ (mm)		28	28	28	28
Solar Coil Connection □ (mm)		22	22	22	22
Secondary Return □ BSP F (‘‘)		0.5	0.5	0.5	0.5
T&P Connection □ BSP F (‘‘)		0.5	0.5	0.5	0.5
3 bar	T&P Press. Set. (bar)	8	8	8	8
	Exp. Relief Set. (bar)	10	10	10	10
Dimesions		200	210	250	300
Cylinder Height A (mm)		1490	1510	1815	2060
Cylinder Diameter B (mm)		540	540	540	540
Connection Height C (mm)		195	195	195	195
Connection Height D (mm)		245	245	245	245
Connection Height E (mm)		335	335	360	360
Connection Height F (mm)		485	485	515	485
Connection Height G (mm)		535	535	565	550
Connection Height H (mm)		600	600	615	615
Connection Height I (mm)		700	700	710	760
Connection Height J (mm)		835	835	1040	1210
Connection Height K (mm)		860	860	1085	1255
Connection Height L (mm)		1010	1010	1350	1390
Connection Height M (mm)		1020	1120	1315	1530
Performance		200	210	250	300
Heat Up Time (10° TO 60°C)		34	37	39	50
1° Re-Heat time (70% dr. off) 15L/m		24	26	27	35
Weight Empty (kg)		77	80	81	90
Weight Full (kg)		257	276	301	347
Prim. Coil Surf. Area (m ²)		2.5	2.5	2.8	3.0
Prim. Coil Rating @ 15L/min (kW)		27.81	27.2	35.26	34.44
Hot Water Capacity (L)		88.8	101	121	155.5
Prim. Coil Pr. Drop @ 15L/min (mbar)		68	68	79	79
Dedicated Solar Volume (ltr)		91.16	95	99	101.5
Solar Coil Surface Area (m ²)		0.58	0.58	0.67	0.67
Heat Exchanger Rated Volume (L)		2.7	2.7	3.2	3.2
Solar Coil Rating @ 15L/min (kW)		15.19	15.2	17.21	17.0
Hot Water Capacity (L)		148	161	192	240
Cont. Output (L/hr)		740	729	902	885

Plumbing G3 Unvented Kit

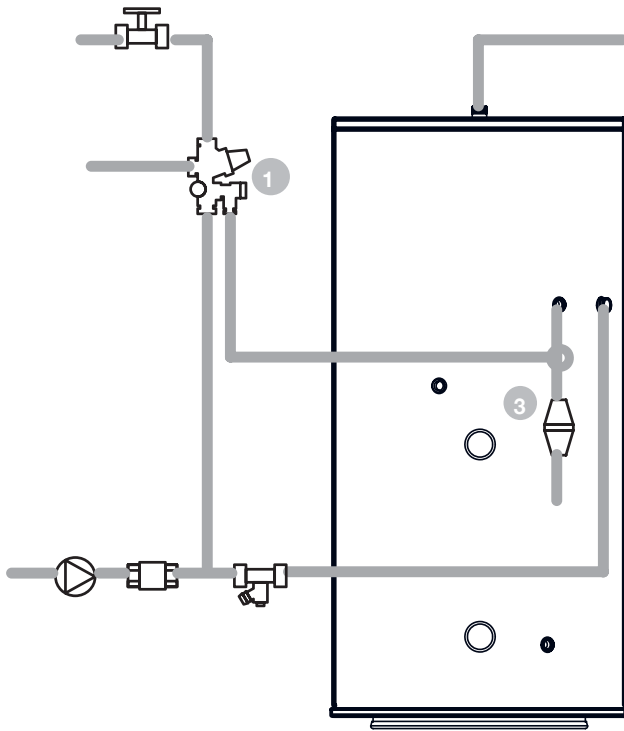

All unvented cylinders must have full G3 kit as supplied with cylinder installed correctly

Inlet Control Group Valve **1** must be fitted on incoming cold feed within 3m of cylinder

Tundish **3** must be fitted on T&P and P relief as shown in this diagram and also reference to **page 43-45** Discharge Arrangement

1



3



Failure to install unvented kit correctly invalidate warranty and does not comply with Building Regulations.

Testing



Do not connect a 6kW Immersion without using a relay switch.

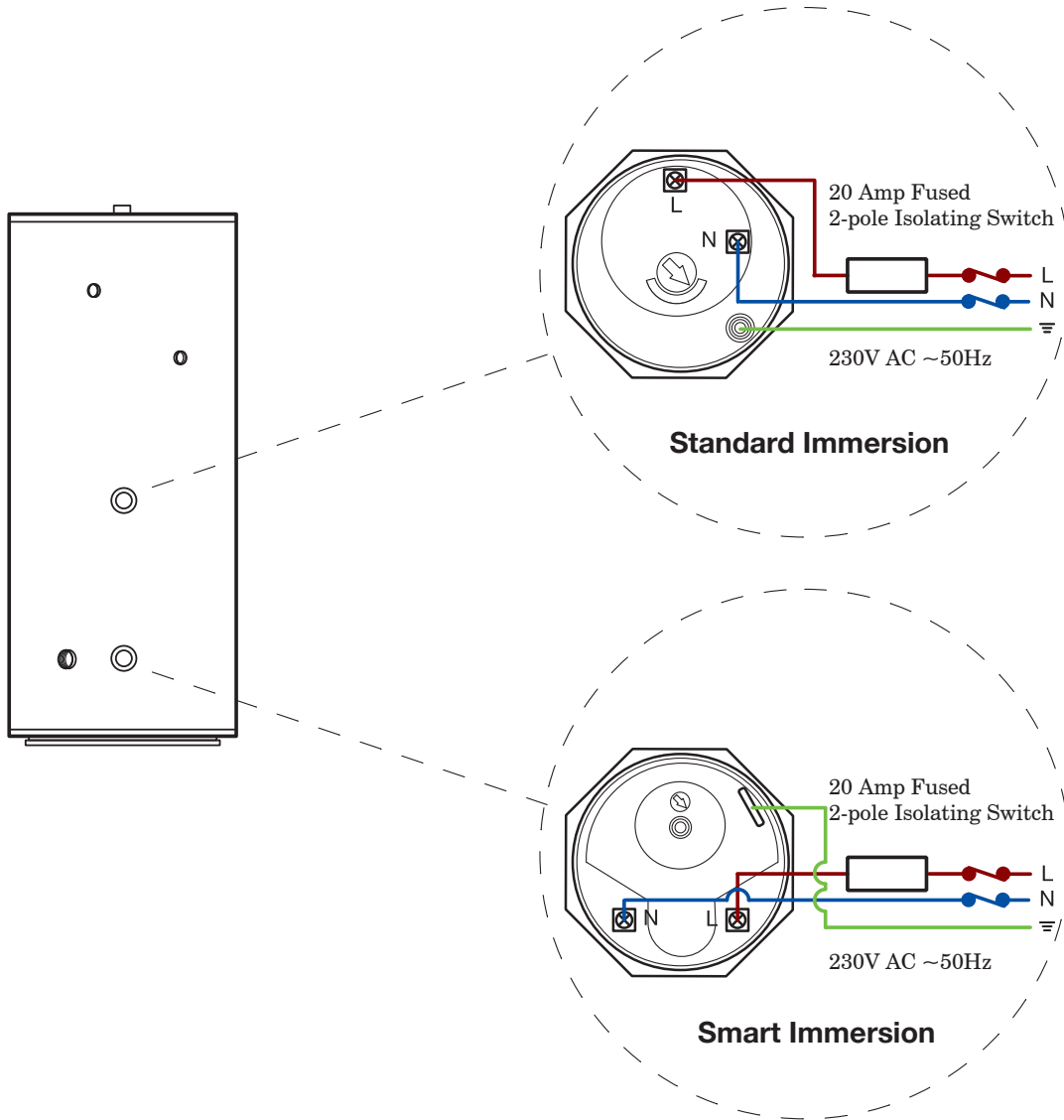

Fitting The Immersion Heater

Always check the immersion for signs of leakage before wiring commences. The immersion heater must be completely submerged in water with a minimum of 200mm of water above the top of the immersion.

Do not operate the immersion heaters until the cylinder has been filled with water

Wire the immersion through a double pole fused spur. The contact separation must be no less than 3mm with a minimum breaking capacity of 16A.

Smart Immersion Functions

On the new Smart Immersion we have four setting options:

- **OFF**
- **ECO** – smart control: starts for 2 weeks at 70°C and then it will select automatically storage temperatures through the day
- **MANUAL** – works as standard mechanical thermostat can be set up to 70°C
- **OPK** (off peak) – this must be selected when the cylinder is connected to the night tariff. During the day time the immersion is not connected and this would require the smart control to be reset. When OPK is selected it should be set at 60°C and working as a standard thermostat. Alternatively the user can select the manual mode.

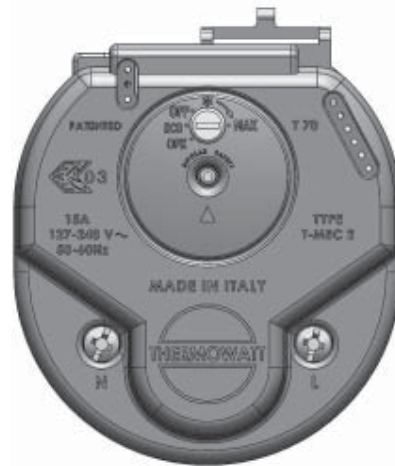

Immersion Testing

Install the immersion using rigid cable, 2m long max, with 2.5 mm² cross-section and a temperature resistance of at least 85°C.

The Cable should be rubber insulated HOFR sheathed, complying with BS6141 Table 8. It must be fully earthed.

Ensure all terminal connections are securely made. Do not however use excessive force when tightening the terminal screws.

Ensure that the power supply is disconnected prior to making any electrical connections. Provide 90mm length of cable for each of the Live and Neutral cables with 8mm of bare cable for connection to the Immersion terminals.

Provide 110mm length of cable for the Earth cable with 20mm of bare cable for connection to the Earth stud.

Make a circle with the bare Earth cable and tighten securely using the washer to the Earth stud. Fit the Live and Neutral cables to the Immersion thermostat.

Ensure all terminal connections are properly tightened prior to commissioning

For installations with high water demands, or areas with hard water, Titanium immersions should be fitted.

The thermostat should be set so that the water is heated to a temperature between 60°C and 65°C. Water stored at temperatures below 60°C can result in bacteria growth and temperatures above 65°C can cause scalding.

The immersion stat has an integrated high limit stat which If the primary thermostat fails the limit thermostat takes over and shuts the element off before the water can boil in the cylinder.

Testing

If there is no hot water you can carry out several tests with your multimeter to decide which component is faulty.

First remove the cover for the wiring and then check for voltage across the live and neutral terminals on the element. If you get a reading the element is faulty (power going through thermostat so stat is working).

Next, check whether the thermostat is working by connecting your multimeter to the live out of the thermostat, if there is no reading the thermostat is faulty.



If the water is getting extremely hot the thermostat is stuck in the 'ON' position and will need to be replaced.

Safety

- Disconnect the immersion from the mains electrical supply before removing any covers.
- Do not attempt to replace the immersion heater(s) with alternatives to those recommended by JOULE™.
- Do not bypass the Thermal Cut-Out(s) in any circumstances.

Replacing The Immersion

First task is to isolate the power. Immersion heaters are rated at 3kW and require their own 20A double pole isolation switch. Turn off the power from the isolation switch and remove the fuse. Next turn off the water to the tank.

Drain the water from the tank via the drain cock using a hose. Remove the immersion using an immersion spanner. Thread in the replacement immersion heater creating the seal using a rubber o-ring or fibre washer. Slot the immersion heater into the hole with the washer and make sure the threads are lined up correctly. Tighten with whichever spanner you are using, taking care not to over tighten and risk damaging the cylinder.

Open the taps up and turn the cold water supply back on. When water starts to come out of the taps shut them off and check for leaks. If all is good wire up the immersion heater, checking that your connections are good. Fit the cap on the immersion and turn the power back on.

If the immersion is connected to a booster switch turn it on and check that it heats up. Economy 7 immersion heaters will only turn on at set times during the night and cannot be altered so check the following morning to see if the water has heated up properly.

Un-Plumbed Cylinder Schematic

Mechanical Diagram S-Plan

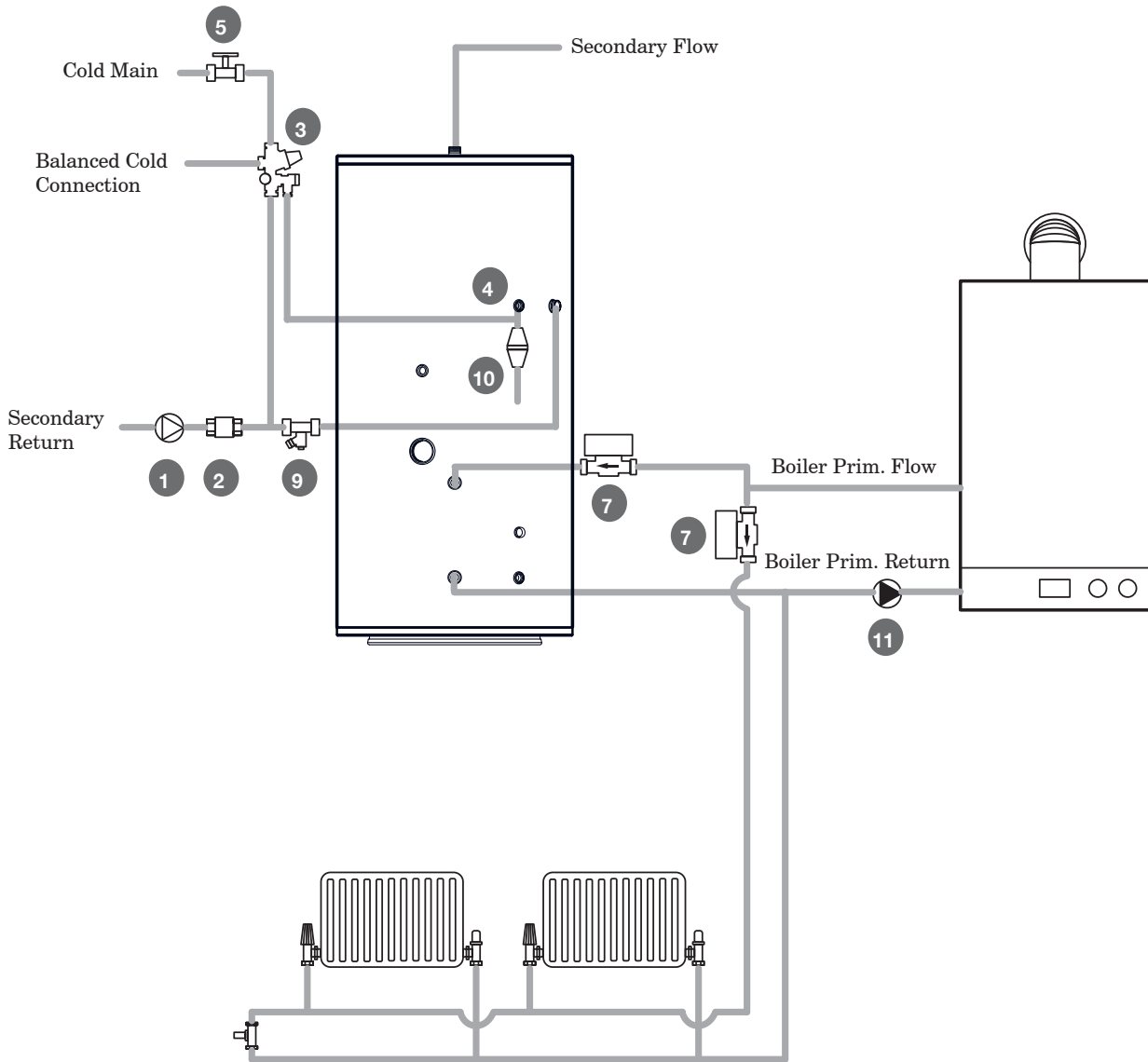

- 1 Bronze Pump
- 2 Non Return Valve (not supplied)
- 3 Inlet Control Group
- 4 Temperature & Pressure Relief Valve
- 6 Isolation Valve (not supplied, must be accessible beside the cylinder)
- 7 2-port Zone Valve
- 8 3-prt Valve (not supplied)
- 9 Drain Valve (not supplied)
- 10 Tundish
- 11 Heating Circ. Pump (required where boiler has no internal pump)



Isolation Valve (not supplied) must be accessible beside the cylinder

Un-Plumbed Cylinder Schematic

Electrical Diagram S-Plan

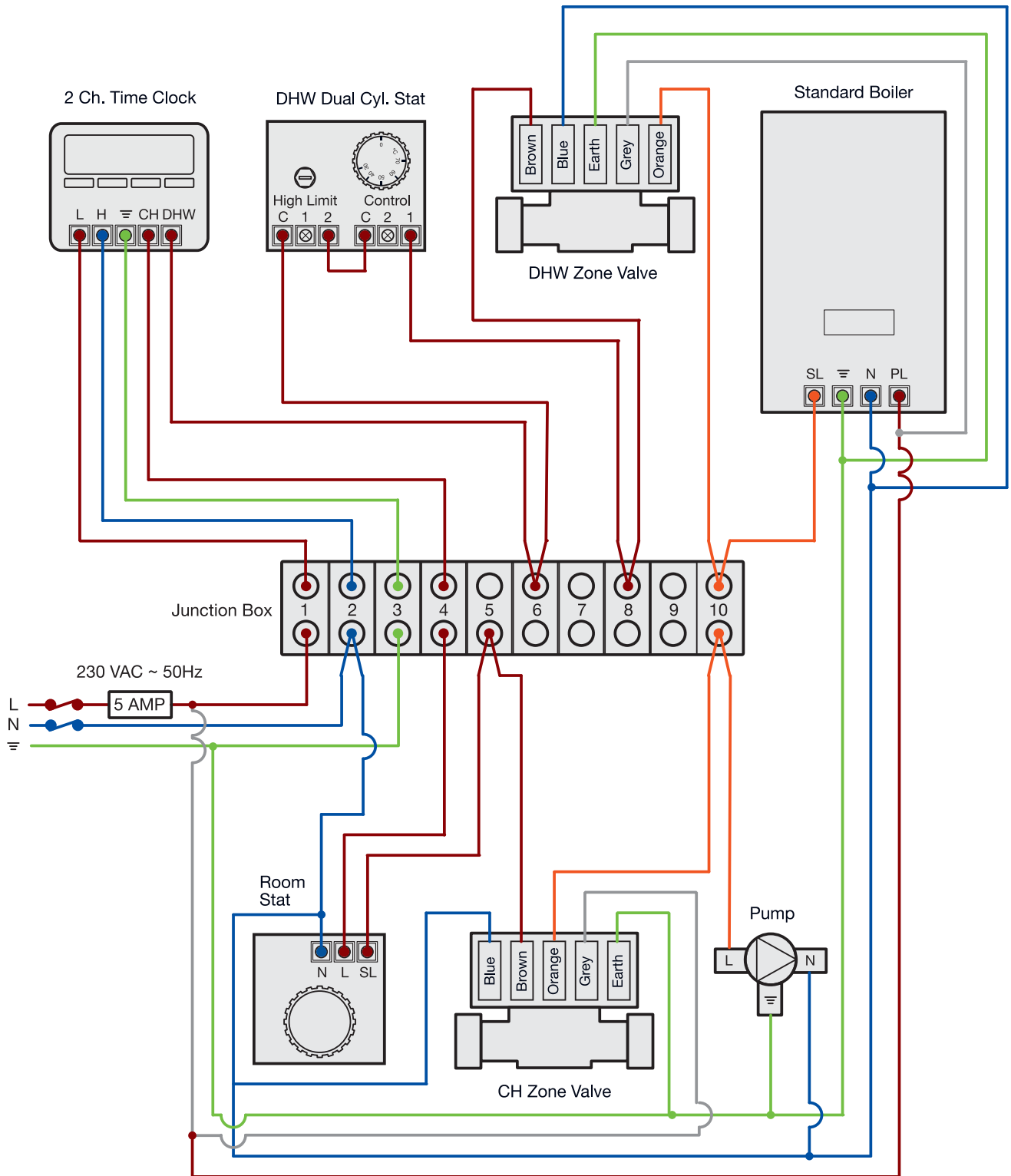

Un-Plumbed Cylinder Schematic

Mechanical Diagram Y-Plan

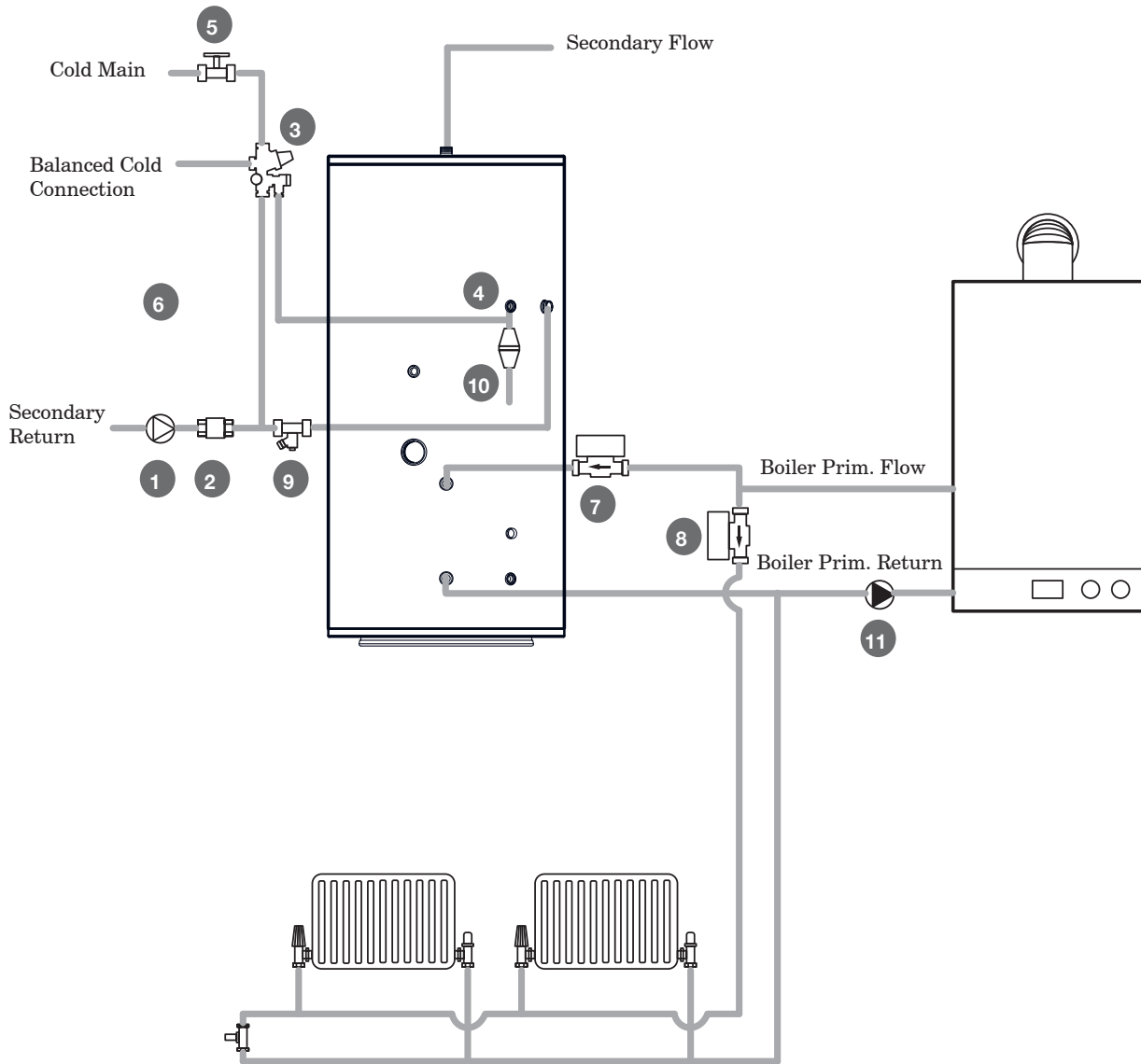

- 1 Bronze Pump
- 2 Non Return Valve (not supplied)
- 3 Inlet Control Group
- 4 Temperature & Pressure Relief Valve
- 6 Isolation Valve (not supplied, must be accessible beside the cylinder)
- 7 2-port Zone Valve
- 8 3-port Valve (not supplied)
- 9 Drain Valve (not supplied)
- 10 Tundish
- 11 Heating Circ. Pump (required where boiler has no internal pump)



Isolation Valve (not supplied) must be accessible beside the cylinder

Un-Plumbed Cylinder Schematic

Electrical Diagram Y-Plan

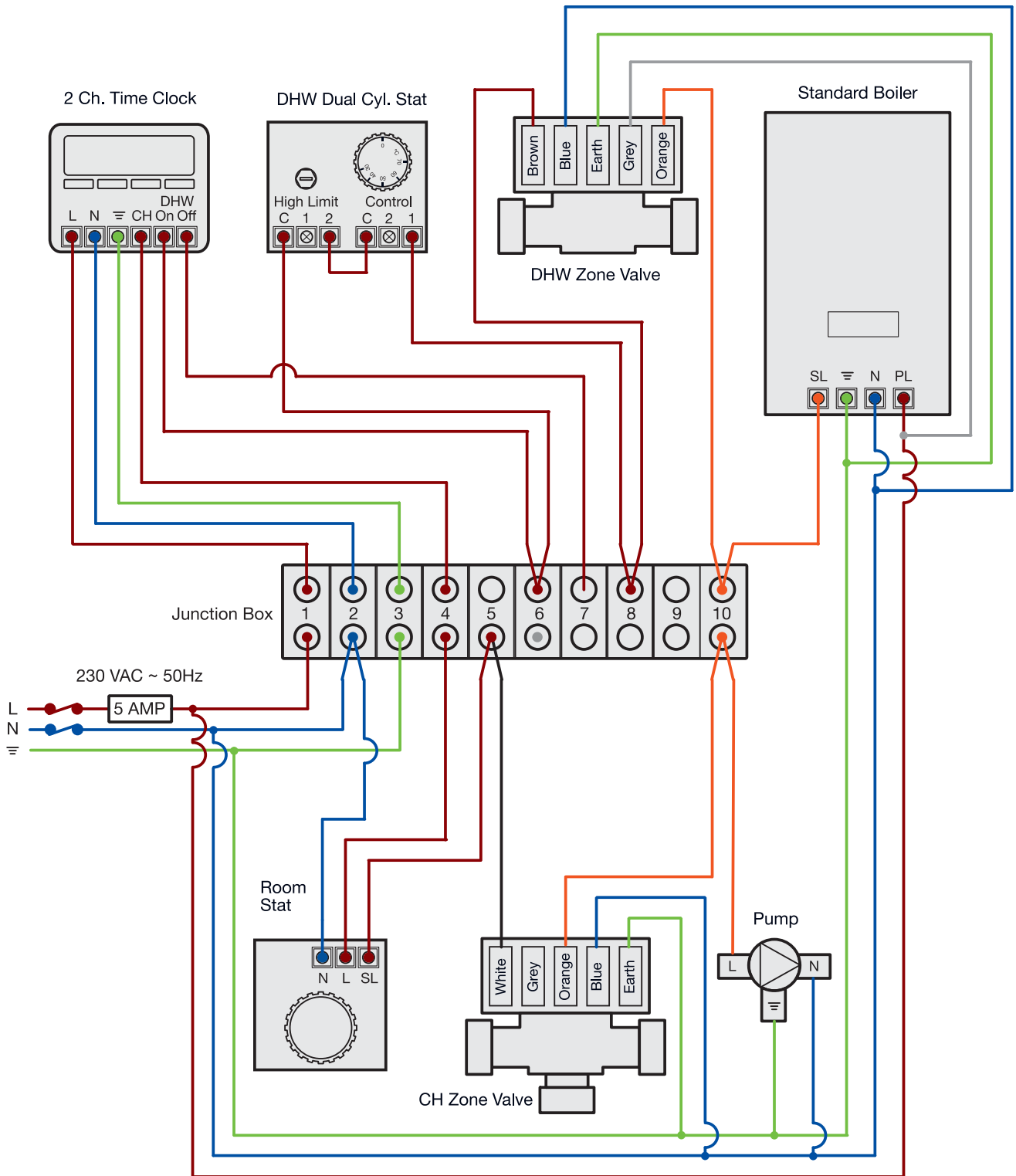

Electronic Controls

Electrical Controls

Suitable time and temperature controls should be installed to allow the cylinder to operate at its maximum efficiency. All electrical work carried out must comply with IEE Wiring Regulations (BS 3456). Products must also be installed as per the regulations in G3 of the Building Regulations. A boiler interlock should be in place and is a wiring arrangement where the boiler cannot fire unless there is a demand for hot water generation.

Typical Wiring Diagrams

These diagrams relate only to the components listed. Others may vary in their wiring requirements, particularly thermostats. Always refer to manufacturers' instructions which may override the detail in order to function correctly.

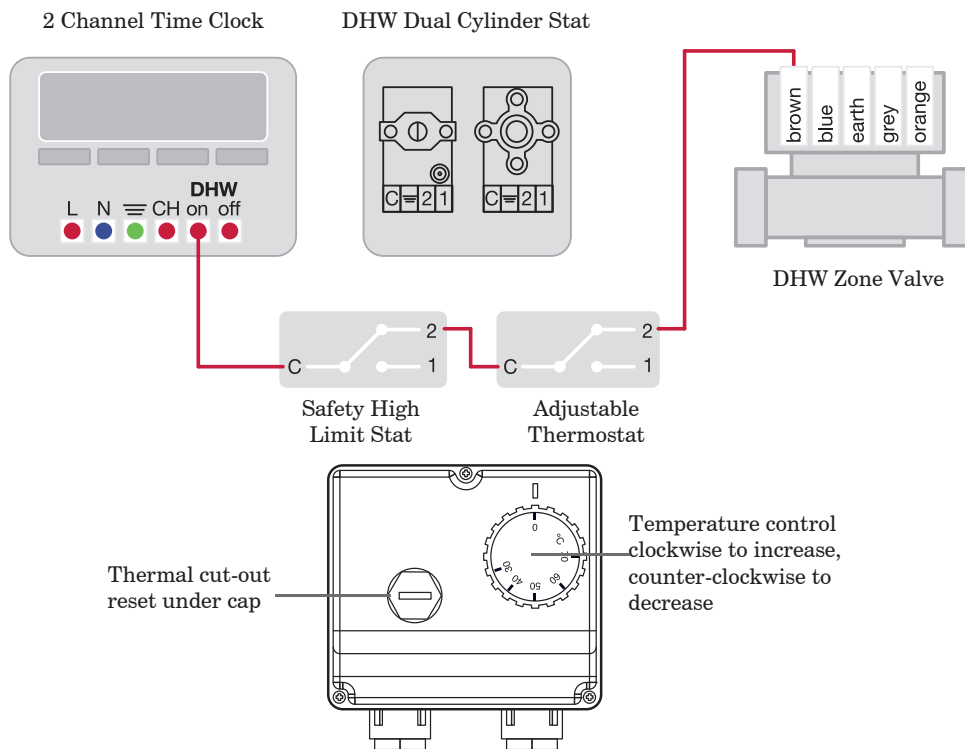

The link must be installed between the adjustable thermostat and the safety cut-out thermostat as shown above. The working thermostat which controls the temperature of the domestic hot water is adjustable. A safety cut out is also incorporated within the thermostat and will operate at $85^{\circ}\text{C} \pm 3^{\circ}\text{C}$. Both thermostats should run in series. To reset the safety cut-out and the motorised valve the reset button must be pressed in.

JOULE™ cannot be responsible if alternative wiring plans are used.



Before resetting the safety cut-out or altering the thermostat setting, isolate electrical supply to the unit before removal of the cover.

Discharge Arrangement

Discharge Pipework

The inlet control group should be positioned so that the discharge from both safety valves can be combined via a 15mm end feed tee, as in the diagram below. Connect the tundish and route the discharge pipe which must be routed in accordance with Building regulation - Part G3 of schedule 1.

When operating normally water will not be discharged. Water discharge from the two safety valves will only occur under fault conditions. The tundish should be vertical, located in the same space as the unvented hot water storage system and be fitted as close as possible, and lower than the valve, with no more than 600mm between the safety device outlet e.g. the temperature relief valve and the tundish.

The position of the tundish must be that when installed it is visible to the occupants of the premises. When positioning the tundish, the drain valves and motorised valve ensure that these items are positioned away from any electrical devices. The discharge pipe (D2) coming from the tundish should terminate in a safe place where there is no risk to persons in the vicinity of the discharge, be of metal and:

- Be at least one pipe size larger than the nominal outlet size of the safety device unless its total equivalent hydraulic resistance exceeds that of a straight pipe 9m long, i.e. discharge pipes between 9m and 18m equivalent resistance length should be at least two sizes larger than the nominal outlet size of the safety device, between 18 and 27m at least 3 sizes larger, and so on.
- Bends must be taken into account in calculating the flow resistance. Refer to diagram 1, Table 1 and the worked example. An alternative approach for sizing discharge pipes would be to follow BS6700 Specification for design, installation, testing and maintenance of services supplying water for domestic use within buildings and their curtilages.
- Have a vertical section of pipe at least 300mm long, below the tundish before any elbows or bends in the pipework.
- Be installed with a continuous fall.

It is preferable for the discharge to be visible at both the tundish and the final point of discharge. Where this is not possible or practically difficult, there should be clear visibility at one or other of these locations.

Discharge Arrangement

Examples Of Acceptable Discharge Arrangements

Ideally below the fixed grating and above the water seal in a trapped gulley.

Downward discharges at a low level; i.e. up to 100mm above external surfaces such as car parks, hard standings, grassed areas etc. are acceptable providing that where children play or otherwise come into contact with discharges, a wire cage or similar guard is positioned to prevent contact whilst maintaining visibility.

Discharges at a high level; e.g. in to metal hopper and metal down pipe with the end of the discharge pipe clearly visible (tundish visible or not) or onto a roof capable of withstanding high temperature discharges of water and 3m from any plastic guttering systems that would collect such discharges (tundish available).

Where a single pipe serves a number of discharges, such as in blocks of flats, the number served should be limited to not more than 6 systems so that any installation can be traced reasonably easily.

The single common discharge pipe should be at least one pipe size larger than the largest individual discharge pipe to be connected. If unvented hot water storage systems are installed where discharges from safety devices may not be apparent, i.e. in dwellings occupied by blind, infirm or disabled people, consideration should be given to the installation of an electronically operated device to warn when discharge takes place.

Worked Example

The example on the next page is for G1/2 temperature relief valve with a discharge pipe (D2) having 4 No. elbows and length of 7m from the tundish to the point of discharge.

Maximum resistance allowed for a straight length of 22mm copper discharge pipe (D2) from a G1/2 temperature relief valve is: 9.0m. Subtract the resistance for 4 No. 22mm elbows at 0.8m each = 3.2m. Therefore the maximum permitted length equates to: 5.8m. 5.8m is less than the actual length of 7m, therefore calculate the next largest size.

Maximum resistance allowed for a straight length of 28mm pipe (D2) from a G1/2 temperature relief valve equates to: 14m. As the actual length is 7m, a 28mm (D2) copper pipe will be satisfactory.

	G 1/2			G 3/4			G1		
Min. size of discharge pipe D1	15mm			22mm			28mm		
Min. size of discharge pipework D2 from tundish	22mm	28mm	35mm	28mm	35mm	42mm	35mm	42mm	54mm
Max. length of straight pipe (no bends or elbows)	Up to 9m	Up to 18m	Up to 27m	Up to 9m	Up to 18m	Up to 27m	Up to 9m	Up to 18m	Up to 27m
Deduct the gure below from the maximum length for each bend or elbow in the discharge pipe	0.8m	1.0m	1.4m	1.0m	1.4m	1.7m	1.4m	1.7m	2.3m

Sizing of copper discharge pipe (D2) for a temp. relief valve with a G1/2 outlet size (as supplied)

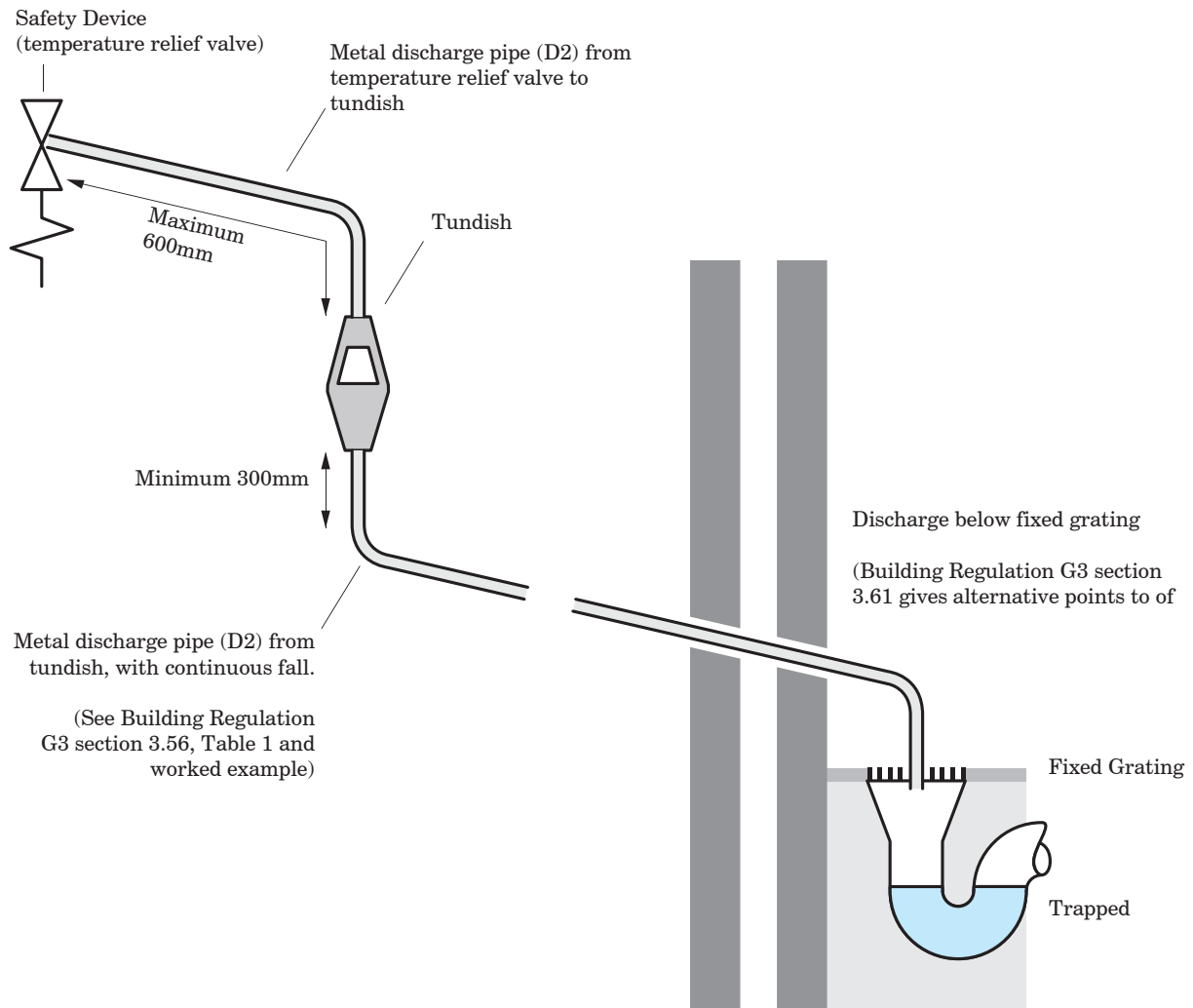

The discharge will consist of scalding water and steam. Asphalt, roofing felt and non-metallic rainwater goods may be damaged by such discharges.

It is not acceptable to discharge straight into a soil pipe.

Commissioning

Pressurising The Air Gap

Ensure that all fittings and immersion heaters are correctly fitted and tightened. An immersion heater key spanner is provided to aid in tightening the immersion heater(s).

1. Open a hot tap furthest from the Cyclone Air.
2. Open the isolating valve located before the Cold Water Combination Valve. Open the mains stop cock to fill the unit. When water issues from the tap, allow to run for a few minutes to thoroughly flush through any residue, dirt or swarf, then close tap.
3. Open successive hot taps to purge any air from the system.
4. Check all connections for leaks and rectify as necessary.
5. The Strainer housed within the Cold Water Combination Valve should be cleaned to remove any debris that may have been flushed through the main supply pipe.

Check The Operation Of The Safety Valves

1. Slowly manually open, for a few seconds, the Temperature and Pressure Relief Valve situated on the Cyclone Air unit. Check water discharged runs freely away through the tundish and discharge pipework. Close valve, ensure water flow stops and valve reseats correctly.
2. Repeat for the Expansion Valve situated on the Cold Water Combination Valve or Expansion Core Unit.

Direct Units

Switch on the electrical supply to the immersion heater(s) and allow the unit to heat up. Check that the thermostat operates correctly. A storage temperature of approx. 60°C is recommended (between graduations 4 and 5 on the thermostat). If necessary the temperature can be adjusted by inserting a flat bladed screwdriver in the adjustment knob on top of the immersion heater thermostat and rotating. The adjustment range 1 to 5 represents a temperature range of between 10°C and 70°C. Check that no water is discharged from either the Expansion Valve or Temperature and Pressure Relief Valve during the heating cycle.

Indirect Units

Fill the indirect (primary) circuit following the boiler manufacturer's commissioning instructions. To ensure the primary heating coil in the Cyclone Air is filled the 2-port motorised valve (supplied) should be manually opened by moving the lever on the motor housing to the MAN OPEN setting. When the primary circuit is full return the lever to the AUTO position. Vent any trapped air by opening the air bleed.

Switch on the boiler, ensure the programmer is set to Domestic Hot Water. Allow the Cyclone Air unit to heat up and check that the indirect thermostat and 2-port motorised valve operate correctly. A storage temperature of approx. 60°C is recommended (approx. graduation 4 on the indirect thermostat). If necessary the temperature can be adjusted by inserting a flat bladed screwdriver in the adjustment knob (located on the front of the thermostat mounting bracket and rotating. The minimum thermostat setting is 10°C. The adjustment range 1 to 5 represents a temperature range of 30°C to 70°C.

Check that no water is discharged from either the Expansion Valve or Temperature and Pressure Relief Valve during the heating cycle.

Benchmark™ Log Book

On completion of the installation and commissioning procedures detailed in this manual the Benchmark™ "Installation, Commissioning and Service Record Log Book" should be completed and signed off by the competent installer or commissioning engineer in the relevant sections.

The various system features, location of system controls, user instructions and what to do in the event of a system failure should be explained to the customer. The customer should then countersign the Benchmark™ log book to accept completion.

The log book should be left with the customer along with these instructions. The log book includes sections that should be filled in when any subsequent service or maintenance operation is carried out on the Cyclone Air.

User Instructions



If water issues from Temperature/Pressure Relief Valve on the Cyclone Air unit Operational Faults section below first. If this does not rectify the fault switch off electrical supply to the immersion heater(s) (Direct units) or shut down the boiler (Indirect units). Do not turn off the water supply. Contact a competent installer for unvented water heaters to check the system.



Do not tamper with any of the safety valves fitted to the Cyclone Air system, if a fault is suspected contact a competent installer.

Temperature Control

Immersion Heaters

A combined thermostat and thermal cut-out is provided for each immersion heater. The thermostat is factory set to give a water storage temperature of approx. 60°C, however it can be set to control between 10°C and 70°C. This will usually have been done during installation. Adjustments can only be made by opening the terminal cover(s), **DO NOT remove the cover(s) without first switching off the electrical supply**. The temperature adjustment is made by inserting a flat bladed screwdriver in the slot in the disc on top of the thermostat and rotating.

If in any doubt consult a competent electrician.

Indirect Units

Indirect units are fitted with an Indirect Thermostat which controls a 2-port motorised valve and hence the temperature of the water in the Cyclone Air unit. The thermostat is factory set to give a water storage temperature of approx. 60°C, however it can be set to control between 10°C and 70°C, this will usually have been done during installation. Adjustments can only be made by opening the terminal cover. **DO NOT remove the cover(s) without first switching off the electrical supply**. Temperature adjustment is made by inserting a flat bladed screwdriver in the adjustment knob located on the front of the thermostat mounting bracket and rotating. At the minimum position the temperature will be approx. 10°C. The adjustment range 1 to 5 represents a temperature range of 30°C to 70°C.

If in any doubt consult a competent electrician.



Do not bypass the thermal cut-out any circumstances

Flow Performance

When initially opening hot outlets a small surge in flow may be noticed as pressures stabilise. This is quite normal with unvented systems and does not indicate a fault. In some areas a cloudiness may be noticed in the hot water. This is due to aeration of the water, is quite normal and will quickly clear.

Operational Faults

Operational faults and their possible causes are detailed on page 49 (Fault Finding). It is recommended that faults should be checked by a competent installer.

The air volume within the Cyclone Air unit will periodically require recharging to ensure any expanded water is accommodated within the unit. A discharge of water **intermittently** from the Expansion Relief Valve will indicate the air volume has reduced to a point where it can no longer accommodate the expansion. To recharge the air volume:

1. Turn off the heat source to the cylinder via programmers/immersion isolation switch(es).
2. Turn off the water supply to the Cyclone Air unit by turning off the isolating valve located before the Cold Water Combination Valve.
3. Open the lowest hot tap supplied by the Cyclone Air.
4. Hold open the Temperature/Pressure Relief Valve until water ceases to run from the tap and gurgling noise at the valve stops.
5. Close Temperature/Pressure Relief Valve.
6. Turn on the isolating valve before the Cold Water Combination Valve by turning the black handle so it lies parallel to the direction of flow, when water flows from the hot tap, close tap.
7. The air volume will be automatically recharged as the unit refills.

If after following the above actions water still discharges from the Expansion Relief Valve further advice should be sought from a competent installer or the JOULE™ Service Department.

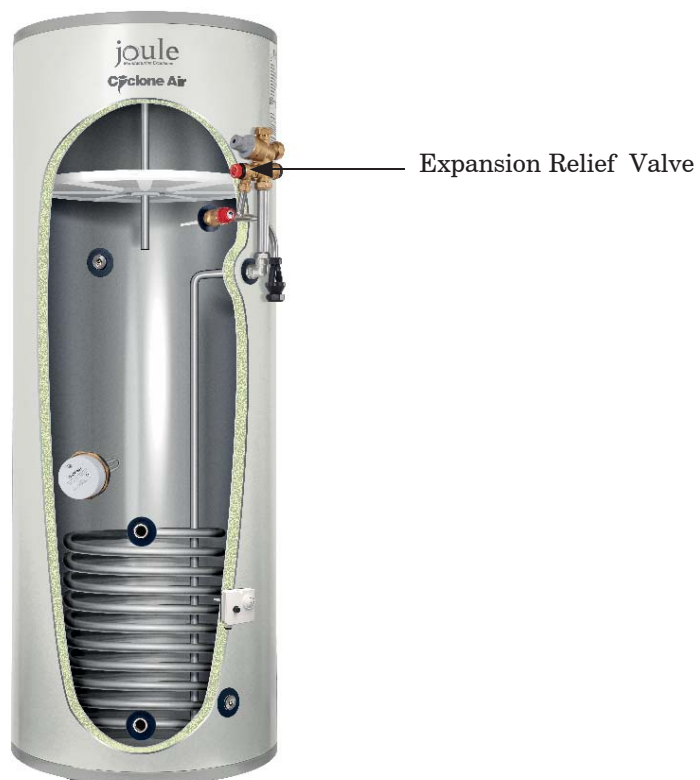

Maintenance

General

Servicing should only be carried out by competent installers and any spare parts used must be purchased from JOULE™.



Never bypass any safety devices or operate the unit without them being fully operational

Draining

Switch the electrical power off (important to avoid damage to element). Isolate boiler from the unit. Turn off the cold water supply valve. Open hot water tap. Open the drain valve. The unit will drain.



Water drained off may be very hot!

Annual Maintenance

The water heaters require annual servicing in order to ensure safe working and optimum performance. It is essential that the following checks are performed by a competent installer on an annual basis. This is commonly done at the same time as the annual boiler service.

- Twist the cap of the expansion relief valve on the inlet control set and allow water to flow for 5 seconds. Release and make sure it resets correctly.
- Repeat with the pressure / temperature relief valve. In both cases check that the discharge pipework is carrying the water away adequately. If not, check for blockages etc. and clear.
- Check that any immersion heaters fitted are working correctly and that they are controlling the water at a temperature between 55°C and 65°C.
- Air or CO₂ may be used to charge the expansion vessel. Unscrew the head on the inlet control set and clean the mesh filter within.

The Service Log Book supplied with this unit should be updated at each service.



Your guarantee may be void if you cannot produce proof of annual servicing immersion heater replacement.

Immersion Heater Replacement

If the thermal cut out on the Immersion heater operates contact a competent installer. If the thermal cut out fault occurs again the immersion will need to be replaced.

Prior to installing the replacement Immersion, ensure the o-ring is correctly positioned on the head of the Immersion and lubricate the threads before fitting.

Thread the Immersion by hand until it is hand tight and then tighten gently to allow the o-rings to create a water tight seal.

Inspection

Where internal inspection of the cylinder is required an endoscope can be used. Inspection can be carried out by draining down the cylinder and removing a component that is fitted to a wet connection in the cylinder.

Safety Valve Checks

From either the temperature/pressure relief valve or the expansion relief valve indicates a problem.

- Check your discharge pipework is free from debris and is carrying water away to waste effectively.
- Next hold both of these safety valves open, allowing as much water as possible to flow through the tundish.
- Release the valves and check that they reseal correctly.



Completion of the Benchmark Checklist on pages 50-51 must be adhered to by the installer

Taking The Cylinder Out Of Use

Shutting Down

- Ensure the cold water supply is isolated and at least two hot water draw off points are open prior to draining the cylinder.
- One of the hot water draw off points should be as close as possible to the height of cylinder in draw off terms.
- Where applicable use the drain valve at the cold water inlet to drain the contents of the cylinder.
- Isolate the coil from the main heating system. If necessary blow out the coil prior to moving the cylinder.

Recycling And Disposal

The cylinder or any of its components must not be disposed of in domestic rubbish. The material in the cylinder, packaging and components contain recyclable materials and they should be disposed of properly and in accordance with national regulations.

Guidance In The Event Of A Problem

If you have a problem in the first year, contact the plumber who fitted the unit. Thereafter contact the plumber who carries out the annual servicing for you. If your cylinder develops a leak we will supply you with a new one. We ask for a nominal upfront payment to prevent fraud and we will require the original unit to be returned to us for inspection along with a copy of your Service Log Book. If it is confirmed that it has failed within the terms of the guarantee your upfront payment will be refunded.

If a component part fails within the guarantee period, we will send you a new one without any upfront charge. Credit card details may be taken to prevent fraud. We ask you to post the faulty part back to us within one month by recorded delivery.

If you do not return the part we will charge you for it and for the postage and packing. If your part fails after the guarantee period, we will ask for upfront payment.

Log Book

The installer must comply with all of the installation instructions contained within this installation manual. On completion of the initial installation and after each subsequent annual service the Benchmark Log Book must be completed and signed by the competent person who has worked the unit.

The purpose of Benchmark is to ensure that customers have the correct equipment for their requirements installed in accordance with the manufacturer's installation instructions. The equipment must be installed by installers who have completed an accredited competent person's scheme and who install, commission and service the equipment in accordance with the manufacturer's instructions.

All installations must comply with the appropriate Building Regulations and the Benchmark Log Book should be provide to the customer. The Benchmark Log Book can also be used to show that all equipment is installed in accordance with the relevant Building Regulations.

Troubleshooting

Your stainless system is automatic in normal use and requires only annual servicing. You should employ a competent installer to perform the annual servicing. Normally this is timed to coincide with the annual boiler service.



If water is flowing from the safety valves through the tundish this indicates a fault condition and action is needed.

If this water is hot, turn the boiler and/or the immersion heater off. Do not turn off the water until the discharge runs cool. The discharge may also stop.

CALL OUT A COMPETENT PLUMBER TO SERVICE THE UNIT.

Tell them you have a fault on an unvented cylinder. We stock all the spare parts they may need and JOULE™ can be contacted via telephone numbers on back page.

Fault	Possible Cause	Solution
Water escaping from the case unit.	Compression fitting on hot - draw off not sealing.	Check / remake joint sealing paste.
Cold water at hot tops.	Immersion heater not switched on or cutout has triggered.	Check / reset.
	Indirect - Boiler not working.	Check boiler - consult boiler manufactures' instructions.
	Indirect - motorized valve fault.	Check plumbing / wiring motorized valve.
	Indirect - cutout in dual stat has operated.	Check for faults in the thermostat or high limit stat and reset.
Water discharges from expansion relief valve	Air gap needs to be recharged.	See page 43.
	If continual - pressure reducing valve (part of inlet control set) may not be operating correctly.	Check outlet pressure from inlet control set is 3 bar.
	If continual - expansion relief valve seat may be damaged.	Remove cartridge - check seat and renew if necessary.
	Unit is being back pressurized.	With cylinder cold check pressure in cylinder. If this is the same as the incoming mains pressure then you are getting backfeed. Install a balanced cold supply.
Water discharges from temperature & pressure relief valve	Unit has overheated - thermal controls have failed.	Switched off power to boiler and immersion heaters. Leave water supply on. Wait until discharges stops. Isolate water supply and replace if faulty.
Milky / cloudy water	Oxygenated Water.	Water from any pressurized system will release oxygen bubbles when flowing. The bubbles will settle out.
No hot water flow	Cold main off.	Check and open stopcock.
	Strainer blocked in pressure reducing valve.	Isolate water supply and clean.
	Inlet control set may be fitted incorrectly.	Check and restart required.
Noise during hot water draw off - typically worse in the morning	Loose airing cupboard pipework.	Install extra clips.
Hot or warm water from cold tap	If tap runs cold after a minute or so the pipe is picking up heat from heating pipework.	Insulate/re-route.

Benchmark Checklist

This Commissioning Checklist is to be completed in full by the competent person who commissioned the storage system as a means of demonstrating compliance with the appropriate Building Regulations and then handed to the customer to keep for future reference.

Failure to install and commission this equipment to the manufacturer's instructions may invalidate the warranty but does not affect statutory rights.

Customer Name _____ Telephone Number _____
 Address _____
 Cylinder Make and Model _____
 Cylinder Serial Number _____
 Commissioned by (print name) _____ Registered Operative ID Number _____
 Company Name _____ Telephone Number _____
 Company Address _____ Commissioning Date _____

To be completed by the customer on receipt of a Building Regulations Compliance Certificate*:

Building Regulations Notification Number (if applicable) _____

ALL SYSTEMS PRIMARY SETTINGS (indirect heating only)

Is the primary circuit a sealed or open vented system? Sealed Open bar

What is the maximum primary flow temperature? _____ °C

ALL SYSTEMS

What is the incoming static cold water pressure at the inlet to the system? _____ bar

Has a strainer been cleaned of installation debris (if fitted)? Yes No

Is the installation in a hard water area (above 200ppm)? Yes No

If yes, has a water scale reducer been fitted? Yes No

What type of scale reducer has been fitted? _____

What is the hot water thermostat set temperature? _____ °C

What is the maximum hot water flow rate at set thermostat temperature (measured at high flow outlet)? _____ l/min

Time and temperature controls have been fitted in compliance with Part L of the Building Regulations? Yes No

Type of control system (if applicable) _____ Y Plan S Plan Other

Is the cylinder solar (or other renewable) compatible? Yes No

What is the hot water temperature at the nearest outlet? _____ °C

All appropriate pipes have been insulated up to 1 metre or the point where they become concealed Yes No

UNVENTED SYSTEMS ONLY

Where is the pressure reducing valve situated (if fitted)?

What is the pressure reducing valve setting? bar

Has a combined temperature and pressure relief valve and expansion valve been fitted and discharge tested? Yes No

The tundish and discharge pipework have been connected and terminated to Part G of the Building Regulations Yes

Are all energy sources fitted with a cut out device? Yes No

Has the expansion vessel or internal air space been checked? Yes No

THERMAL STORES ONLY

What store temperature is achievable?

°C

What is the maximum hot water temperature?

°C

ALL INSTALLATIONS

The hot water system complies with the appropriate Building Regulations Yes

The system has been installed and commissioned in accordance with the manufacturer's instructions Yes

The system controls have been demonstrated to and understood by the customer Yes

The manufacturer's literature, including Benchmark Checklist and Service Record, has been explained and left with the customer Yes

Commissioning Engineer's Signature _____

Customer's Signature _____

(To confirm satisfactory demonstration and receipt of manufacturer's literature)

*All installations in England and Wales must be notified to Local Authority Building Control (LABC) either directly or through a Competent Persons Scheme. A Building Regulations Compliance Certificate will then be issued to the customer.



www.centralheating.co.uk

Service Record

It is recommended that your hot water system is serviced regularly and that the appropriate Service Record's completed.

Service Provider

Before completing the appropriate Service Record below, please ensure you have carried out the service as described in the manufacturer's instructions.

Service 1	Date
Engineer Name	
Company Name	
Telephone No	
Comments	
.....	
.....	
.....	
Signature	

Service 1	Date
Engineer Name	
Company Name	
Telephone No	
Comments	
.....	
.....	
.....	
Signature	

Service 1	Date
Engineer Name	
Company Name	
Telephone No	
Comments	
.....	
.....	
.....	
Signature	

Service 1	Date
Engineer Name	
Company Name	
Telephone No	
Comments	
.....	
.....	
.....	
Signature	

Service 1	Date
Engineer Name	
Company Name	
Telephone No	
Comments	
.....	
.....	
.....	
Signature	

Service 1	Date
Engineer Name	
Company Name	
Telephone No	
Comments	
.....	
.....	
.....	
Signature	

Service 1	Date
Engineer Name	
Company Name	
Telephone No	
Comments	
.....	
.....	
.....	
Signature	

Service 1	Date
Engineer Name	
Company Name	
Telephone No	
Comments	
.....	
.....	
.....	
Signature	

Service 1	Date
Engineer Name	
Company Name	
Telephone No	
Comments	
.....	
.....	
.....	
Signature	

Service 1	Date
Engineer Name	
Company Name	
Telephone No	
Comments	
.....	
.....	
.....	
Signature	

JOULE IE

mail Kylemore Park West, Ballyfermot, Dublin
tel 10
fax +353 (1) 623 7080
eml +353 (1) 626 9337
web info@joule.ie
www.joule.ie

JOULE PL

mail 23-200 Kraśnik, ul. Towarowa 34.
tel +48 (0) 128811171
fax +48 (0) 814709046
eml biuro@joule-pl.pl
web www.joule-pl.pl

JOULE UK

mail Unit 17C&D Power Road, Plantation Bus.
Pk. Bromborough, Wirral, CH62 3RN
tel +44 (0) 1513 551 094
fax +44 (0) 1513 568 336
eml info@jouleuk.co.uk
web www.jouleuk.co.uk